

Mikasa

REVERSIBLE COMPACTOR

MVH-308

MVH-408

MVH-508

INSTRUCTION MANUAL

Contents of "Declaration of Conformity"

YR® YOUNG/MAN
RICHARDSON
& CO. LTD.

Please refer the
EC DECLARATION OF CONFORMITY
in this manual as well.

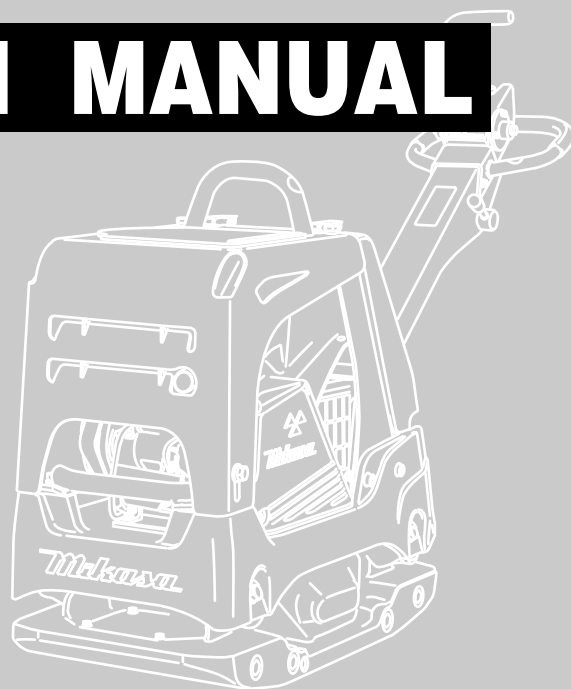

MIKASA SANGYO CO.,LTD.

402-07403

1) DECLARATION OF CONFORMITY

2) Manufacturer's name and address.	Mikasa Sangyo Co., Ltd. 4-3, Sarugaku-cho 1 chome, Chiyoda-ku, Tokyo101-0064, Japan					
3) Name and address of the person who keeps the technical documentation.	Yoshiharu Nishimaki, engineer R. & D. Division, Mikasa Sangyo Co., Ltd. Shiraoka-city, Saitama, Japan					
4) Type: Vibratory Plates						
5) model	MVH-308DSZ	MVH-408DSZ	MVH-508DSZ			
6) Equipment item number	454100, 454101, 454113, 454114, 454115, 454116, 454117, 454118, 454119, 454120, 454121, 454122 454136	454200, 454202, 454211, 454212, 454213, 454214, 454215, 454216, 454217, 454218, 454219, 454220 454234	454300, 454301, 454306, 454307, 454308, 454309, 454310, 454311, 454312, 454313, 454314, 454315, 454316, 454317 454333			
7) Serial number	For serial number, please refer it on front page.					
8) power source cont. output <max. output>	Hatz 1B30 4.9kW <5.4kW>	Hatz 1B50 6.7kW <7.3kW>	Hatz 1D81S 8.9kW			
9) Measured sound power level(dB)	107	107	108			
10) Guaranteed sound power level(dB)	108	108	109			
11) Operator's sound pressure level(dB)	93	94	94			
12) Conformity assessment according to Annex:	VIII (Full Quality Assurance procedure)					
13) Name and address of the Notified Body	Société Nationale de Certification et d'Homologation (SNCH) 11, route de Luxembourg L-5230 Sandweiler LUXEMBOURG					
14) Related Directive	Directive 2000/14/EC and, to be followed by Directive 2005/88/EC , relating to the noise emission in the environment by equipment for use outdoors.					
15) Declaration	The equipment referred in this document, fulfills with all the requirements of Directive 2000/14/EC					
16) Other related Community Directives	2006/42/EC, 2005/88/EC, 2004/108/EC, 2002/88/EC(2004/26/EC) EN500-1, EN500-4					
17) EC Conformity Certificate No:	SNCH*2000/14*2005/88*0472*03					
18) Place and date of the declaration	Tokyo, Japan December, 2013 Signed by:  _____ Keiichi YOSHIDA Director, Product Control Division Mikasa Sangyo Co., Ltd.					

1) DECLARATION OF CONFORMITY

2) Manufacturer's name and address.	Mikasa Sangyo Co., Ltd. 4-3, Sarugaku-cho 1 chome, Chiyoda-ku, Tokyo101-0064, Japan					
3) Name and address of the person who keeps the technical documentation.	Yoshiharu Nishimaki, engineer R. & D. Division, Mikasa Sangyo Co., Ltd. Shiraoka-city, Saitama, Japan					
4) Type: Vibratory Plates						
5) model	MVH-308GH	MVH-308GE	MVH-408GH			
6) Equipment item number	454102, 454105, 454108, 454123, 454124, 454125, 454126	454111, 454112, 454127, 454128	454202, 454205, 454208, 454221, 454222, 454223			
7) Serial number	For serial number, please refer it on front page.					
8) power source cont. output <max. output>	Honda GX270 5.1kW <6.0kW>	Subaru EX27 5.1kW <6.6kW>	Honda GX390 6.6kW <8.2kW>			
9) Measured sound power level(dB)	105	106	106			
10) Guaranteed sound power level(dB)	107	107	107			
11) Operator's sound pressure level(dB)	93	94	94			
12) Conformity assessment according to Annex:	VIII (Full Quality Assurance procedure)					
13) Name and address of the Notified Body	Société Nationale de Certification et d'Homologation (SNCH) 11, route de Luxembourg L-5230 Sandweiler LUXEMBOURG					
14) Related Directive	Directive 2000/14/EC and, to be followed by Directive 2005/88/EC , relating to the noise emission in the environment by equipment for use outdoors.					
15) Declaration	The equipment referred in this document, fulfills with all the requirements of Directive 2000/14/EC					
16) Other related Community Directives	2006/42/EC, 2005/88/EC, 2004/108/EC, 2002/88/EC(2004/26/EC) EN500-1, EN500-4					
17) EC Conformity Certificate No:	SNCH*2000/14*2005/88*0472*03					
18) Place and date of the declaration	Tokyo, Japan March, 2014 Signed by:  _____ Keiichi YOSHIDA Director, Product Control Division Mikasa Sangyo Co., Ltd.					

Italian

1. DICHIARAZIONE "CE" DI CONFORMITÀ
2. Nome e indirizzo Fabbricante
3. Nome e indirizzo della persona che conserva la documentazione tecnica
4. Tipo: **Piastre vibranti**
5. Modello
6. Codice macchina
7. Numeridi matricola
8. Potenza installata netta <resa massima>
9. Livello di potenza sonora misurato (dB)
10. Livello di potenza sonora garantito
11. Livello massimo di pressione sonora
12. Valutazione di conformità in accordo all'annesso VIII (procedura Garanzia di Qualità totale
13. Nome dell'organismo notificato
14. Rappresentante Autorizzato in Europa
15. Direttiva di riferimento
Direttiva 2000/14/CE su l'emissione acustica ambientale delle macchine ed attrezzature destinate a funzionare all'aperto
16. Dichiarazione
Le attrezzature riportate nel documento soddisfano i requisiti della Direttiva 2000/14/CE
17. Altre Direttive Comunitarie di riferimento
18. Certificato di Conformità CE No:
19. Luogo e data della dichiarazione

French

1. DECLARATION « CE » DE CONFORMITE
2. Non et adresse du Fabricant
3. Nom et adresse de la personne qui défient les documents techniques
4. Type du materiel: **Plaques vibrantes**
5. Modello
6. Numero equipement
7. Numéro de série
8. Puissance reseau <rendement maximal>
9. Niveau sonore mesure(dB)
10. Niveau sonore garanti(dB)
11. Niveau sonore maximum
12. Certification de conformite selon l'annexe VIII (procedura

Garanzia di Qualità totale)

13. Nom et adresse de l'organisme notifié
14. Mandataire dans la Communauté Européenne
15. Directive concernee
Est également conforme aux dispositions de la directive <<emission sonores des equipements utilises a l'exterieur des batiments>> 2000/14/CE et aux legislations nationales la transposant.
16. Declaration
L'équipement de référence satisfait aux exigences de la Directive 2000/14/EC
17. Autres directives communautaires concernees
18. Certificate deConformite CE numero:
19. Lieu et date de la declaratio

Spanish

1. DECLARACIÓN "CE" DE CONFORMIDAD
2. Nombre y dirección del fabricante
3. Nombre y dirección de la persona que guarda la documentación técnica.
4. Tipo: **Bandejas vibrantes**
5. Modelo
6. Número de referencia del equipo
7. Numeros de serie
8. Potencia neta instlada <rendimineto maximo>
9. Nivel sonoro medido del motor (dB)
10. Nivel sonoro garantizado del motor (dB)
11. Máximo nivel sonoro de presión (dB)
12. Evaluación de la Conformidad de acuerdo al Anexo VIII (Prcedimiento de total garantía asegurada)
13. Nombre y dirección de la Entidad Notificada
14. Representante autorizado
15. Directiva relacionada
Directiva 2000/14/CE en relación a la emisión sonora en el ambiente por equipos que trabajan en espacios abiertos
16. Declaración
El equipo referido en este documento , cumple con todos los requerimientos de la Directiva 2000/14/EC
17. Otras Directivas Comunitarias relacionadas
18. Certificado de Conformidad CE Nº
19. Lugar y fecha de la declaración

Table of contents

1. INTRODUCTION	1
2. APPLICATION, STRUCTURE AND POWER TRANSMISSION	1
3. WARNING SIGNS	2
4. CAUTIONS FOR SAFETY.....	2
4.1 General Cautions	2
4.2 Refueling Precautions	3
4.3 Location And Ventilation Precautions	3
4.4 Precautions Before Starting	3
4.5 Precautions During Work	3
4.6 Lifting Precautions	3
4.7 Transportation And Storage Precautions	3
4.8 Maintenance Precautions	4
4.9 Label Position	5
4.10 Descriptions Of Symbols Used On Warning Labels	7
4.11 Control Unit Positions And Names	8
5. SPECIFICATION.....	9
6. APPEARANCE	11
7. INSPECTION BEFORE OPERATION	12
7.1 Engine Oil	12
7.2 Vibration Case Oil	12
7.3 Refueling	12
7.4 Handle	13
8. OPERATION	13
8.1 Starting	13
8.2 Operation	16
8.3 Compaction Sensor (Compas)	16
9. STOPPING THE MACHINE.....	18
10. TRANSPORTAION AND STORAGE.....	19
10.1 Care	19
10.2 Transportation Precautions	19
10.3 Storage	19
11. REGULAR CHECK AND ADJUSTMENT.....	20
11.1 Inspection And Maintenance Schedule Table	20
11.2 Open The Front Cover	21
11.3 Changing The Engine Oil	22
11.4 Cleaning The Air Cleaner	22
11.5 Checking/Changing The V-belt	22
11.6 Checking/Changing The vibrator Oil	23
11.7 Checking/Changing The Hydraulic Oil	23
11.8 Battery	24
12. TROUBLESHOOTING	26
13. WIRING DIAGRAM	29

1. INTRODUCTION

- This operation manual describes the proper operation, basic inspection and maintenance procedures of the reversible compactor. Please read this operation manual before use in order to maximize the excellent performance of this machine and make your work more efficient and effective.
- After reading the manual, please keep it in a handy location for easy reference.
- For the handling the engine, please refer to the separate engine operation manual.
- For inquiries about repair parts, parts lists, service manuals, and repairs, please contact the store where you purchased the product, our sales office, or the Mikasa Parts Service Center. For parts lists, please visit our homepage at: <http://www.mikasas.com/> where you can access Mikasa WEB parts lists.

The illustrations in this manual might slightly differ in part from the machine you actually purchased due to design changes.

2. APPLICATION, STRUCTURE AND POWER TRANSMISSION

Application

This machine, weighing more than 200kg to more than 400kg, is a compactor with back and forth motion. The strong vibration from the two-axes pendulum structure inside the vibrator changes the machine's motion into straight back and forth motion. The machine compacts through this motion.

The machine has tightening and compacting effect for all ground types other than the soft soil with high water percentage. Because the machine is capable of straight back and forth movement, it works very effectively in grooved structures. Also, since the work efficiency of this machine is high, it is suitable for compacting of a large area. The machine also works well for flattening and leveling rough ground surface with irregularities created by the use of a powerful tamping rammer.

The machine can be used widely for heavy compacting works such as base work as well as finishing work for asphalt paving.

Warning About Incorrect Applications And Techniques

Do not use this machine on ground with a high water percentage and, in particular, do not use on clay because the machine will not advance. Use this machine for compacting earth and sand mixtures, soil, sand or gravel. Do not use this machine for other type of work.

Structure

The upper part of the machine consists of an engine, handle, belt cover and exterior frame. The upper part of the machine is fixed to the vibrating plate of the lower part via an anti-vibration rubber. The lower part of this machine consists of a vibrating plate that incorporates a vibrator, there are two pendulums. The phase of those pendulums is changed by hydraulic pressure.

The hydraulic cylinder for the vibrator is connected with a hydraulic hose to the hydraulic pump, which is directly connected to the drive lever.

Power Transmission

Power is provided by an air-cooled single-cylinder 4-cycle gasoline engine or diesel engine. The engine output shaft is equipped with a centrifugal clutch. The centrifugal clutch is engaged when the engine speed increases. V-pulley is incorporated to the centrifugal clutch drum, and power is transmitted via the V-belt to the V-pulley on the vibrator side.

Through this process, the engine revolution is changed to the pendulum revolution suitable for compacting.

The vibrator pulley rotates the pendulum axis of the drive side. The two pendulums inside the vibrator are fixed to the two pendulum axes that are positioned in parallel and are connected with the gear. The two axes rotate in opposite directions at the same speed to generate vibration.





There is a spiral groove on the inner periphery of the gear assembled on the pendulum axis to be driven. This groove serves as a key groove to let the guide pin slide to the axis direction. This guide pin is connecting the two pendulum axes. The phase of the two pendulums is changed by the axial sliding of the guide pin. The change in phase causes the vibration to change directions, thus changing the speed and travel direction of the machine.

Hydraulic pressure is used for the axial movement of the guide pin. At the end of the groove where the guide pin is attached, a piston is installed. When the oil level rises inside the hydraulic cylinder on the vibrator side and the pressure increases, the piston is pushed. Then the axis connected to the piston is pushed, which causes the guide pin attached to the axis to move, resulting in a change in phase.

The operator of the machine, by using the back and forth motion lever of the handle, can adjust the oil quantity and pressure by the connected hand pump to get the travel speed suitable for the work.

3. WARNING SIGNS

The triangle shaped  marks used in this manual and on the decals stuck on the main body indicate common hazards. Be sure to read and observe the cautions described.

 Warning labels indicating hazards to humans and to equipment.	
 DANGER	Denotes an extreme hazard. It calls attention to a procedure, practice, condition or the like, which, if not correctly performed or adhered to, is likely to result in serious injury or death.
 WARNING	Denotes a hazard. It calls attention to a procedure, practice, condition or the like, which, if not correctly performed or adhered to, could result in serious injury or death.
 CAUTION	Denotes a hazard. It calls attention to a procedure, practice, condition or the like, which, if not correctly performed or adhered to, could result in injury to people and may damage or destroy the product.
CAUTION (without at )	Failure to follow the instructions may result in damage to property.

4. CAUTIONS FOR SAFETY

4.1 General Cautions

WARNING

- Do not work with this machine, when
 - you are tired or sick and not feeling well,
 - you have taken medicine or drug, or
 - you have had a drink.



CAUTION

- Please read the operation manual well and work safely by using the machine properly.
- For handling of the engine, please refer to the separate engine operation manual.
- Please have a good understanding of the structure of this machine.
- Make sure to do work start inspection, regular self inspection and specified self inspection.
- To make your work safe, please use protective equipment (use specified helmet, protective shoes, etc.) and wear appropriate work clothes.
- Always use noise protection equipment such as ear muffs or ear plugs.
- Always check the machine to make sure it is in normal condition before operating the machine.
- The nameplates attached to the machine (nameplates showing operation method, warning, etc.) are very important for your safety. Clean the machine so that the nameplates can be read easily. If it is difficult to read the nameplate, please replace the old one with a new one.
- It is dangerous for young children to come near the machine. Please pay careful attention to the method of storing and the storage location for this machine. Especially the engine start key has to be taken out every time you finish your work, and keep it in a designated location.
- To do maintenance work, stop the engine and remove the battery wiring.
- We are not responsible for accidents that have occurred after the machine was refurbished without approval from the manufacturer.



4.2 Refueling Precautions

DANGER

- Always refuel in a well ventilated area.
- Make sure to stop the engine and wait until the engine cools down when refueling.
- Select a flat surface area with no flammable material around for refueling. Be careful not to spill the fuel. Wipe off well if there is any spill.
- Never put fire near the machine during refueling. (Especially, be careful about smoking.)
- If you fill to the top of the fuel tank inlet, fuel might spill out from the tank, and it becomes dangerous
- After refueling, tighten the tank cap well.



4.3 Location And Ventilation Precautions

DANGER

- Do not run the machine in an unventilated location, such as indoors or inside a tunnel. The exhaust gas from the engine contains toxic gases such as carbon monoxide and is very hazardous.
- Do not operate the machine near open flames.



4.4 Precautions Before Starting

CAUTION

- Check each part to see if it is tightened properly. Vibration causes loosening of bolts, which results in unexpected serious malfunctions of the machine. Tighten the bolts securely.

4.5 Precautions During Work

CAUTION

- Before starting the machine, make sure it is safe to start by checking your surroundings for people and objects.
- Always pay attention to your footing. Work in an area where you can maintain a good balance of the machine and a safe comfortable posture.
- The engine and muffler become very hot. Do not touch immediately after the machine stops because they are still very hot.
- If you notice deterioration of machine operation during your work, stop your work immediately.
- Before moving away from the machine, be sure to turn the engine off. Also when the machine is transported, stop the engine and close the fuel cock.
- For a machine with cell starter specification, do not operate without the battery. If you operate without the battery, electrical system failure might occur.



4.6 Lifting Precautions

DANGER

- Before lifting, check the machine parts (especially the hook and anti-vibration rubber) for any damage and loosened or missing bolts.
- Stop the engine and shut the fuel cock while lifting.
- Use a sufficiently strong wire rope.
- For lifting, use only one point hoisting hook, and do not lift at any other part.
- When the machine is hoisted, never let people or animals come underneath.
- For safety reasons, do not lift to a height that is higher than necessary.



4.7 Transportation And Storage Precautions

WARNING

- Stop the engine during transportation.
- Transport after the engine and the machine are cooled down.
- Always drain the fuel before transporting.
Securely fix the machine to prevent it from moving or falling during transportation.



4.8 Maintenance Precautions

WARNING

- Appropriate maintenance is required to ensure safe and efficient operation of the machine. Always pay attention to the machine's condition and keep it in good condition. Pay special attention to the parts used for lifting, if they are not maintained properly, it might result in a serious accident.
- Start maintenance work after the machine has cooled down completely. The muffler, in particular, becomes very hot, and there is a danger of burn. The engine, engine oil and vibrator also become very hot. Be careful not to get burned.



CAUTION

- Always stop the engine before inspection and adjustment. If you are caught in a rotating part, serious injury might occur.
- After maintenance work, check the security parts to see if they are securely installed. Special attention should be paid when checking bolts and nuts.
- If disassembly is involved in maintenance, refer to the maintenance instruction manual to make your work safe.



About The Battery

DANGER

- If the battery fixing bolts have been removed, put them back and tighten securely to fix the battery.
If used with the battery not fixed properly, contact with the battery terminal might occur, leading to electric shock and electric leak, or breakage of the battery might occur by the impact and vibration from outside, resulting in battery fluid leakage.
- The gas from the battery might cause an explosion. Do not generate sparks or bring flames near the battery.
- Never put the positive terminal and negative terminal come into contact. Sparks will be generated, and ignition might occur.

WARNING

- Be careful when handling the battery fluid because it is very toxic. If the battery fluid gets on your skin, eye, or clothes, rinse it off with plenty of water and consult with a doctor.

4.9 Label Position

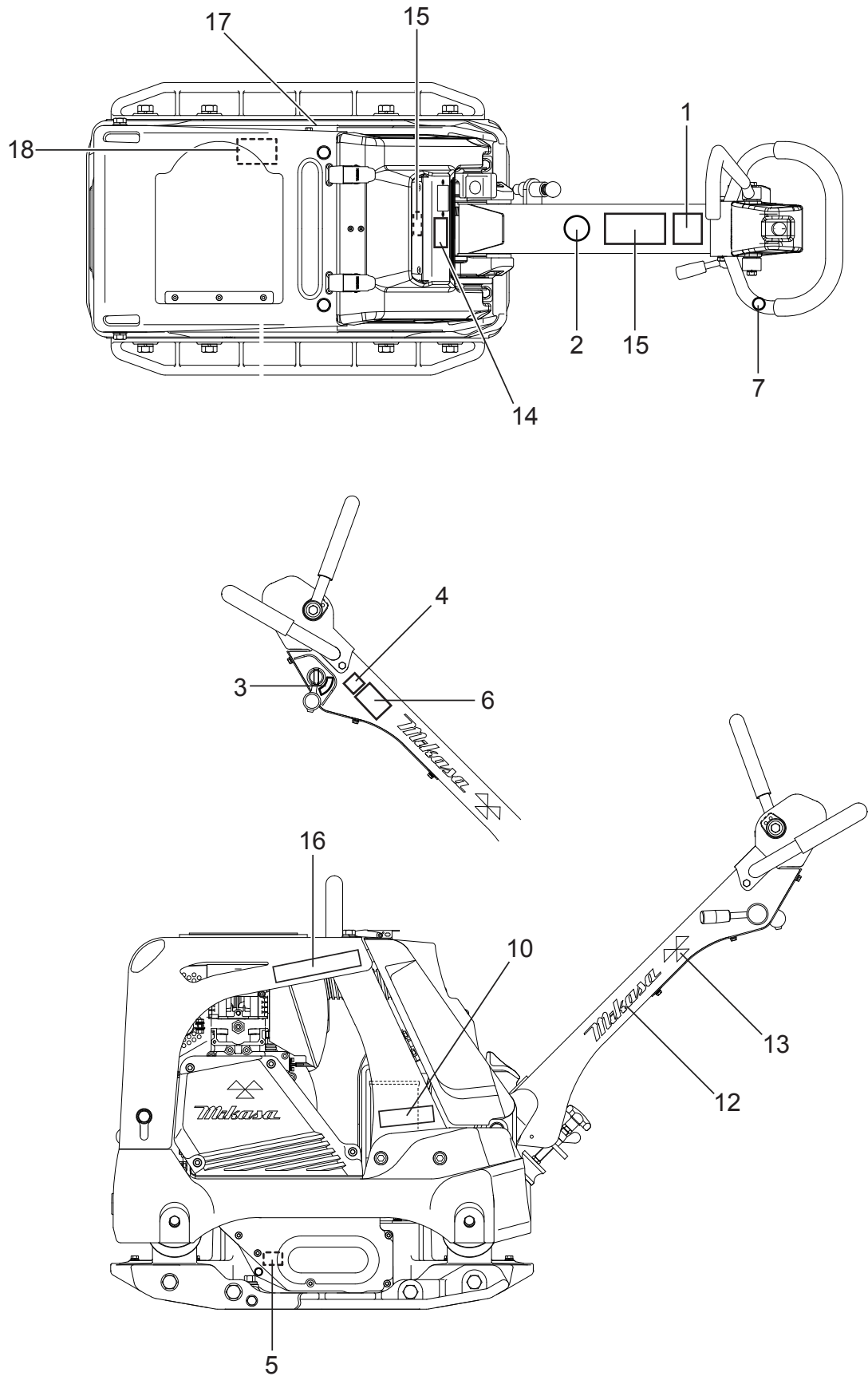



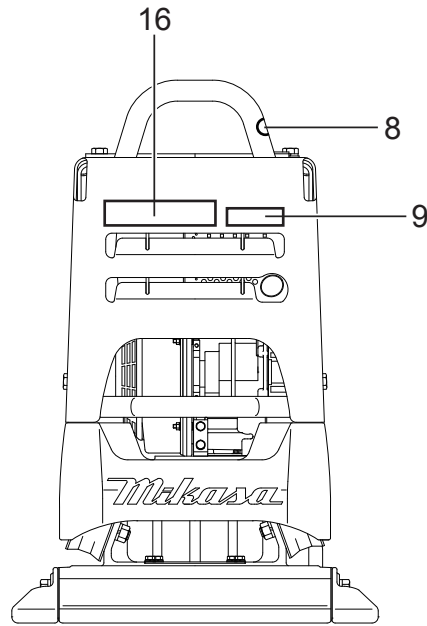





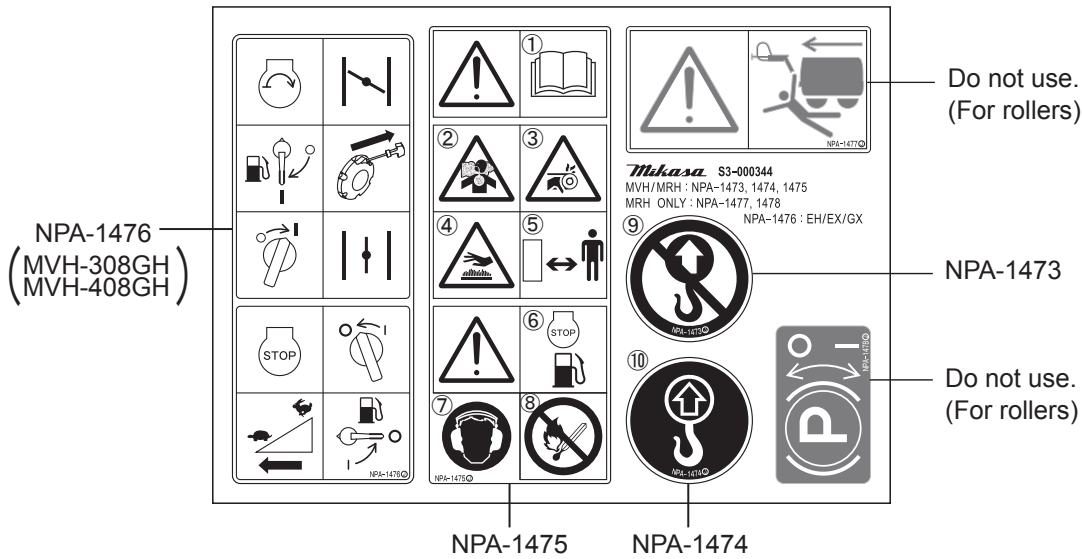

※ The illustration is shown for model, "MVH-308"

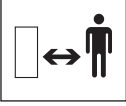

REF No.	PART No.	PART NAME	Q'TY	REMARK
1	9202-10100	DECAL,EC NOISE REQ.LWA108	1	
2	9202-03330	EAR PROTECTION LABEL	1	
3	9201-08800	DECAL, KEY SWITCH	1	
4	9202-14960	DECAL, KEY OPERATION	1	
5	9202-01950	DECAL,OIL SAE 10W-30	1	
6	9202-14950	DECAL,REMOVE KEY	1	
7	9202-14730	DECAL,DO NOT LIFTING	1	
8	9202-14740	DEAL,LIFTING POSITION	1	
9	9202-17640	DECAL COMPASS MARK 94MM	1	Diesel Only
10	9202-17650	DECAL COMPASS MARK 110MM	2	Diesel Only
11	9202-14750	DEAL,CAUTION ICONS/V-TYPE	1	
12	9202-17130	DECAL,MIKASA MARK(W)200L	2	
13	9202-17110	DECAL, MIKASA MARK 35X70	2	
14	9202-18140	DECAL, E/G RPM 3400	1	308D
14	9202-18130	DECAL, E/G RPM 3600	1	308G
14	9202-18150	DECAL, E/G RPM 2400	1	408D,508D
14	9202-18160	DECAL, E/G RPM 3200	1	408G
15	9202-17870	DECAL, MODEL MVH-308	1	308
15	9202-17880	DECAL, MODEL MVH-408	1	408
15	9202-17890	DECAL, MODEL MVH-508	1	508
16	9202-17730	DECAL,MODEL MVH-308 R-OR	2	308
16	9202-17770	DECAL,MODEL MVH-408 R-OR	2	408
16	9202-17810	DECAL,MODEL MVH-508 R-OR	2	508
17	9202-17740	DECAL,MODEL MVH-308 L-OR	1	308
17	9202-17780	DECAL,MODEL MVH-408 L-OR	1	408
17	9202-17820	DECAL,MODEL MVH-508 L-OR	1	508
18	—————	PLATE,SERIAL NO.	1	Not For Sale

4.10 Descriptions Of Symbols Used On Warning Labels



- ①  **Read the manual carefully.**
Always read the operation manual and have good understanding of operation before your work.
- ②  **Danger: poisonous exhaust gas**
Carbon monoxide poisoning may occur if the exhaust gas is inhaled. Do not operate the machine in a poorly ventilated area.
- ③  **Be careful not to be caught in rotating parts.**
Make sure the engine is stopped when removing the belt cover during a belt change.
- ④  **Be careful not to get burned.**
Accidental burn may occur if you touch the hot parts (engine, muffler, etc.) during operation or immediately after the machine stops.
- ⑤  **Be careful not to approach danger source.**
During operation, Be careful not to approach hot parts and rotating parts.
- ⑥  **Refueling Hazard.**
Don't fill the fuel tank while the engine is running or hot.
- ⑦  **Danger of hearing damage caused by noise**
Always use ear plugs while operating the machine.
- ⑧  **Fire hazard**
Stop the engine when refueling. Fire may occur if a flame is near the tank fuel port.
- ⑨  **Do not lift the machine at this point.**
Lifting by the handle is prohibited.
- ⑩  **Lifting position.**
For lifting, use only one point hoisting hook, and do not lift at any other part.

Starting, and stopping (Refer to engine instruction manual for Diesel engine type) P/N 9209-00110 DECAL, SET /MVH, MRH /EXP, EU (NPA-1476 : "Diesel engine type" is excluded.)

START

- ① Open Fuel Cock to start
- ② Turn Stop Switch to "I"(ON) position
- ③ Close Choke Lever
- ④ Pull Recoil Starter to start
- ⑤ Return Choke Lever to open

STOP

- ① Return Throttle Lever fully until "O"(OFF) position to stop work
- ② After cooling down enough, stop the engine to move Stop Switch to "O"(OFF) position
- ③ Close Fuel Cock at the end

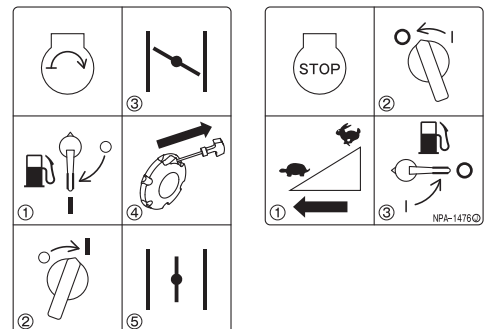

4.11 Control Unit Positions And Names

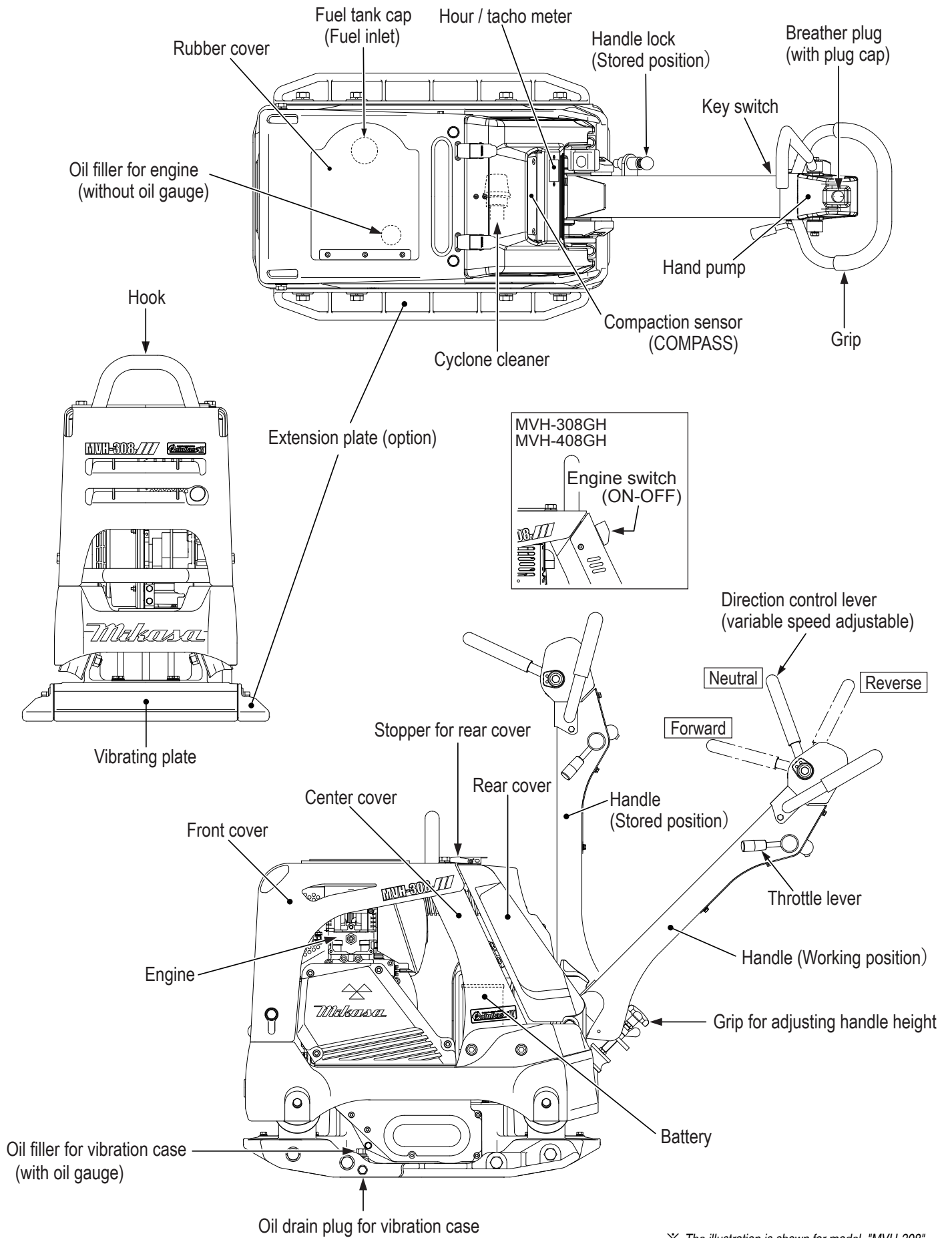

※ The illustration is shown for model, "MVH-308"

5. SPECIFICATION

MODEL		MVH-308DSZ MVH-308DSZ-PAS	MVH-308DSY MVH-308DSY-PAS	MVH-408DSZ MVH-408DSZ-PAS
Main Dimensions				
Overall Length	mm	1540	1540	1570
Overall Height (Handle)	mm	1030	1030	1030
Overall Width	mm	445(595,745)	445(595,745)	500(650,800)
Compacting Board				
Width	mm	445(595,745)	445(595,745)	500(650,800)
Length	mm	860	860	900
Weight				
Operating Weight	kg	345(360,375)	341(356,371)	408(423,438)
Engine				
Manufacturer/Type		HATZ,1B30	YANMAR,L70N6	HATZ,1B50
Type Of Engine		Air-cooled 4-cycle diesel engine	Air-cooled 4-cycle diesel engine	Air-cooled 4-cycle diesel engine
Maximum Power	kw/min ⁻¹ PS/min ⁻¹	4.9/3300 6.7/3300	4.9/3600 6.7/3600	6.7/2500 9.1/2500
Set Engine Revolution	r.p.m	3350	3600	2350
Electric Start		○	○	○
Performance				
Vibrating Frequency	Hz/VPM	73/4400	73/4400	73/4400
Centrifugal Force	kN/kgf	45/4600	45/4600	55/5600
Max. Traveling Speed	m/min	0~27	0~27	0~28
Hand Arm Vibration (Ahv)	m/sec ²	6.1	—	4.7

MODEL		MVH-408DSY MVH-408DSY-PAS	MVH-508DSZ MVH-508DSZ-PAS
Main Dimensions			
Overall Length	mm	1570	1600
Overall Height (Handle)	mm	1030	1070
Overall Width	mm	500(650,800)	650(800)
Compacting Board			
Width	mm	500(650,800)	650(800)
Length	mm	900	900
Weight			
Operating Weight	kg	407(422,437)	525(540)
Engine			
Manufacturer/Type		YANMAR,L100N2	HATZ,1D81
Type Of Engine		Air-cooled 4-cycle diesel engine	Air-cooled 4-cycle diesel engine
Maximum Power	kw/min ⁻¹ PS/min ⁻¹	7.0/3200 9.5/3200	8.9/2500 12.1/2500
Set Engine Revolution	r.p.m	3200	2350
Electric Start		○	○
Performance			
Vibrating Frequency	Hz/VPM	73/4400	69/4150
Centrifugal Force	kN/kgf	50/5100	65/6600
Max. Traveling Speed	m/min	0~27	0~29
Hand Arm Vibration (Ahv)	m/sec ²	—	5.5

※ The number in parentheses is the dimension of the “extension plate(option)” with.
“()”: MVH-308,408: (standard type, wide type)
MVH-508: (wide type)

MODEL		MVH-308GH	MVH-308GE	MVH-408GH
Main Dimensions				
Overall Length	mm	1540	1540	1570
Overall Height (Handle)	mm	1030	1030	1030
Overall Width	mm	445(595,745)	445(595,745)	500(650,800)
Compacting Board				
Width	mm	445(595,745)	445(595,745)	500(650,800)
Length	mm	860	860	900
Weight				
Operating Weight	kg	310(325,340)	307(322,337)	364(379,394)
Engine				
Manufacturer/Type		HONDA,GX270	ROBIN,EX27	HONDA,GX390
Type Of Engine		Air-cooled 4-cycle petrol engine	Air-cooled 4-cycle petrol engine	Air-cooled 4-cycle petrol engine
Maximum Power	kw/min ⁻¹ PS/min ⁻¹	6.3/3600 8.6/3600	6.6/4000 9.0/4000	8.7/3600 11.9/3600
Set Engine Revolution	r.p.m	3600	3600	3200
Electric Start		×	×	×
Performance				
Vibrating Frequency	Hz/VPM	73/4400	73/4400	73/4400
Centrifugal Force	kN/kgf	45/4600	45/4600	55/5600
Max. Traveling Speed	m/min	0~27	0~27	0~28
Hand Arm Vibration (Ahv)	m/sec ²	2.8	3.8	3.7

Remarks:

Vibration Level is in comply with EU Directive 2002/44/EC and the value is shown as 3 axis min vibration level.
Test course (Crushed gravel) is in comply with EN500-4.

The above values are subject to change in case that the machine is modified or/and the required regulations change.

※ The number in parentheses is the dimension of the “extension plate(option)” with.
“()”: MVH-308,408: (standard type, wide type)
MVH-508: (wide type)

6. APPEARANCE

MVH-308 MVH-408

※ The illustration is shown for model, "MVH-308"

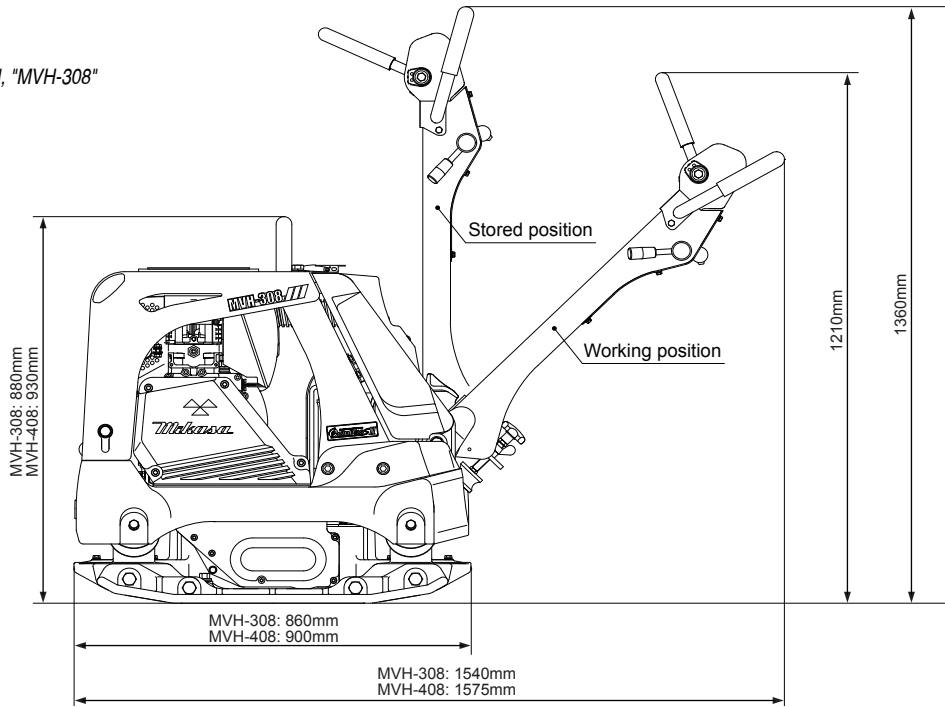
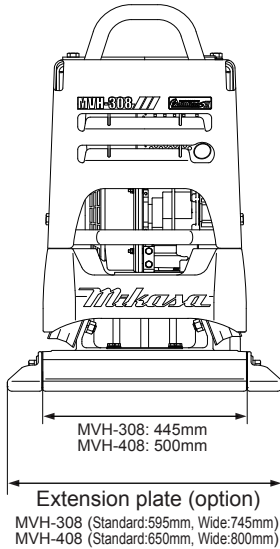

MVH-508

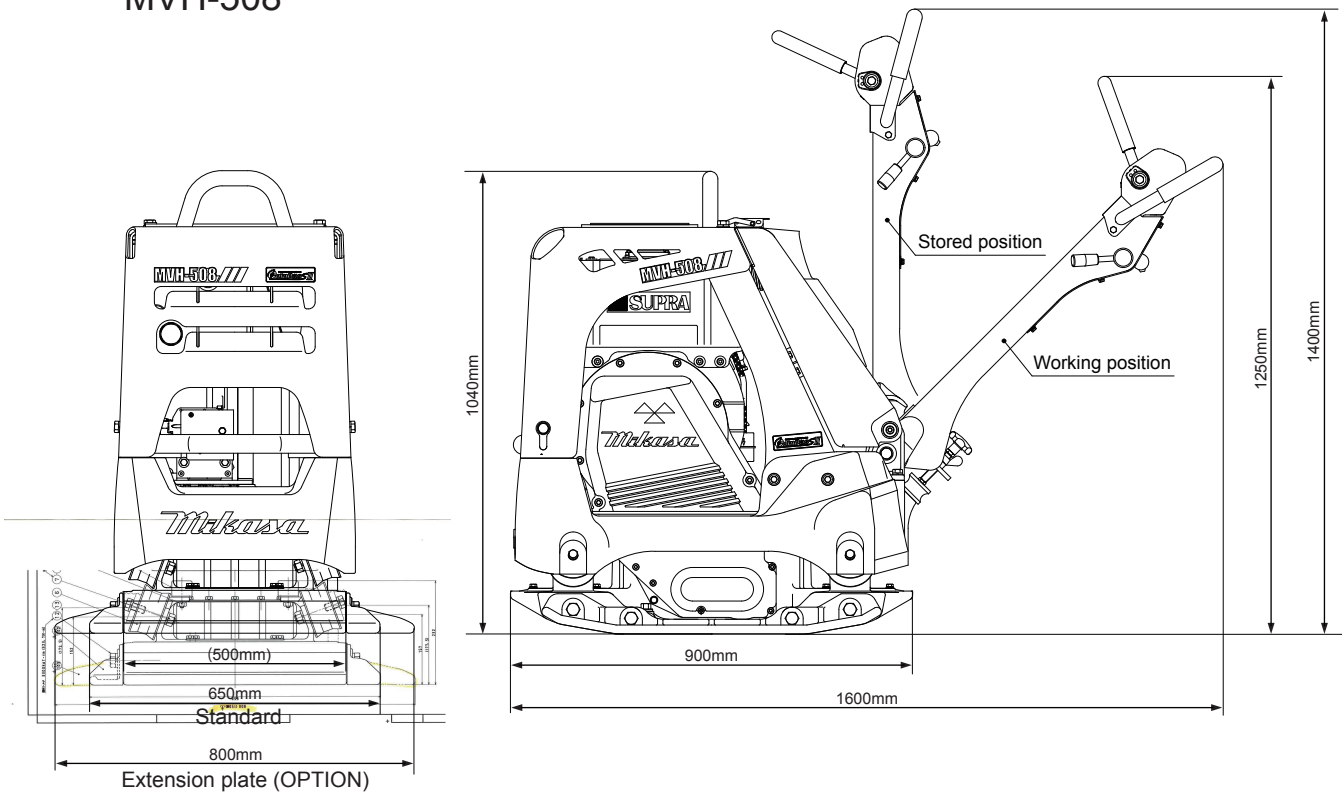

7. INSPECTION BEFORE OPERATION

Part inspection sheet before work start

Check point	Check item
Visual inspection	Crack, Skewness
Front cover & center cover	Falling off, Breakage, Crack, Looseness and falling off of bolt & nuts
Fuel tank	Leak, Quantity of oil, Dirt
Fuel system	Leak
Fuel filter	Dirt
Engine oil	Leak, Quantity of oil, Dirt
Vibration case oil	Leak, Quantity of oil, Dirt
V-belt for vibrator	Crack, Tension
Oil pressure pipe line system	Leak, Looseness, Crack, Abrasion
Traveling lever & part of system	Falling off, Breakage, Crack, Looseness and falling off of bolt & nuts
Operation of traveling lever, rink origin	Operation check, Permissible error
Bolt, nuts	Looseness, Falling off

The check is details of engine is referred to engine instruction manual independently.

⚠ CAUTION

Always stop the engine before inspection

7.1 Engine Oil

- Set the engine on a level surface to check the oil level. If the oil level is low, add oil. (Fig.1)
Only lubrication can be done from the top for HATZ engine (1B and 1D). (There is no oil gauge.) (Fig.2)
Use the following engine oil.

Quality: Diesel engine oil, Grade CC or above
Gasoline engine oil, Grade SE or above
Viscosity: SAE No. 30 at 20°C and above (summer)
SAE10W-30

- ※ When pouring oil from the top (for 1B and 1D), oil might overflow if large amount of oil is poured at one time. So, pour slowly.

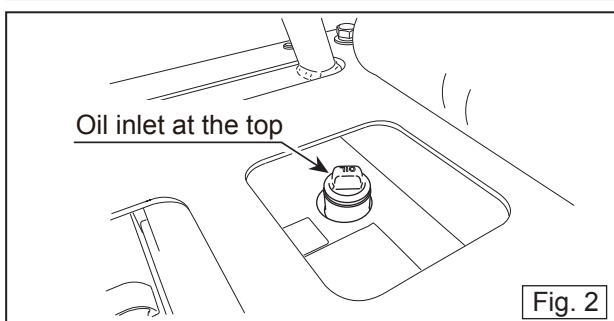
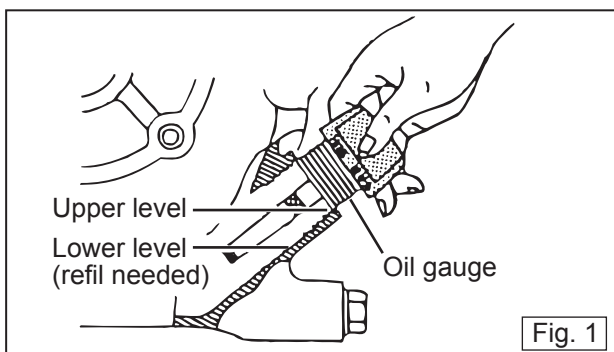

7.2 Vibration Case Oil

- Set the machine on a level surface, then remove the oil gauge of the vibrator. Check the oil gauge to see if the oil is at the specified level. Use engine oil SAE10W-30 as lubrication oil.
Recommended oil quantity is 600cc. (Fig. 3)

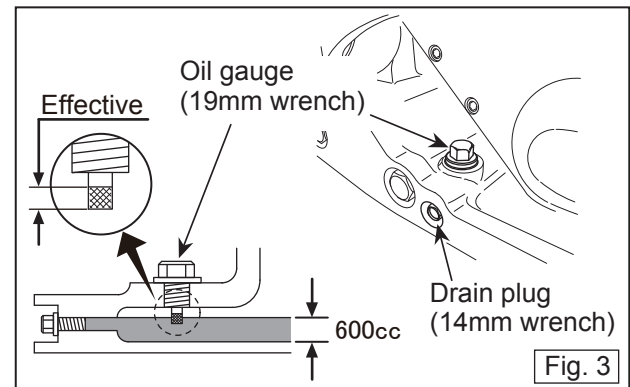

7.3 Refueling

⚠ DANGER

- Stop the engine when refueling.
- Do not expose to open flames while refueling.
- Do not fill to the rim because the fuel might spill.
- Wipe off well if a spill occurs.
- Use clean automotive gasoline or automotive light oil appropriate for the engine. Let the fuel run through a filter when refueling.
- Fuel inlet is located under the rubber cover at the front cover top portion.
- The fuel tank cap is equipped with a lock lever. Unlock this lever before opening the cap. (Only for HATZ engine) (Fig.4)

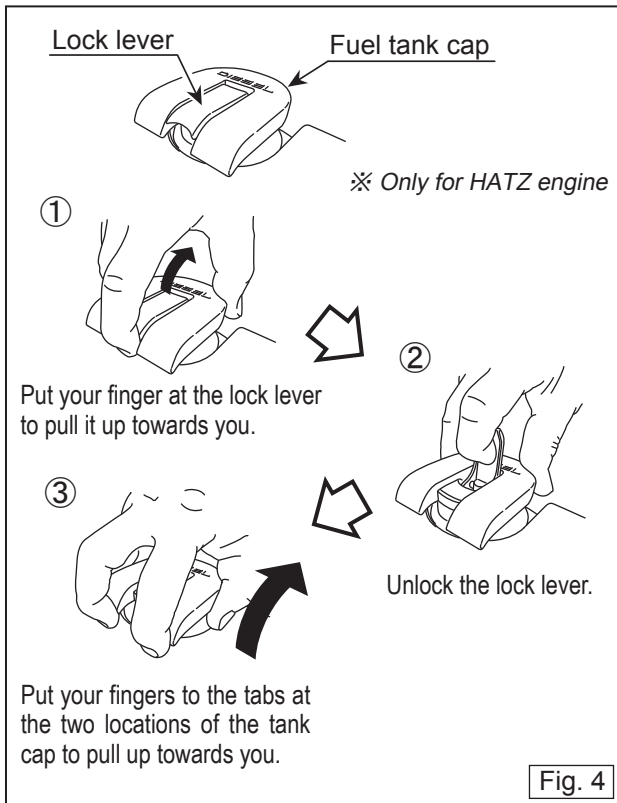

7.4 Handle

The height of the handle is adjustable for your comfort.(Fig.5)

Adjusting Handle height

Loosen the wing nut. Turn the grip clockwise to raise the handle or counter clockwise to lower the handle. When the handle is raised to the desired height, tighten the wing nut.

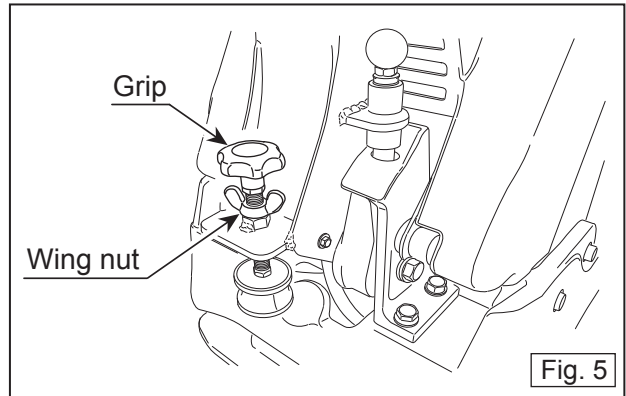

8. OPERATION

8.1 Starting

Gasoline Engine

- 1 Set the fuel cock lever to the "ON" position to let the fuel flow. (Fig. 6)

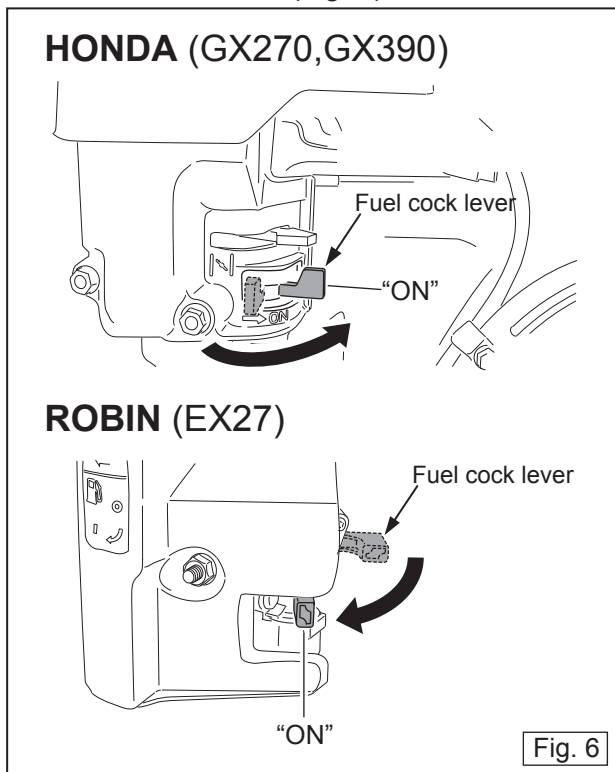

- 2 In cold weather or when the engine does not start easily, set the choke lever to the "Start" position. This is not necessary when the engine is already warmed up. (Fig. 7)

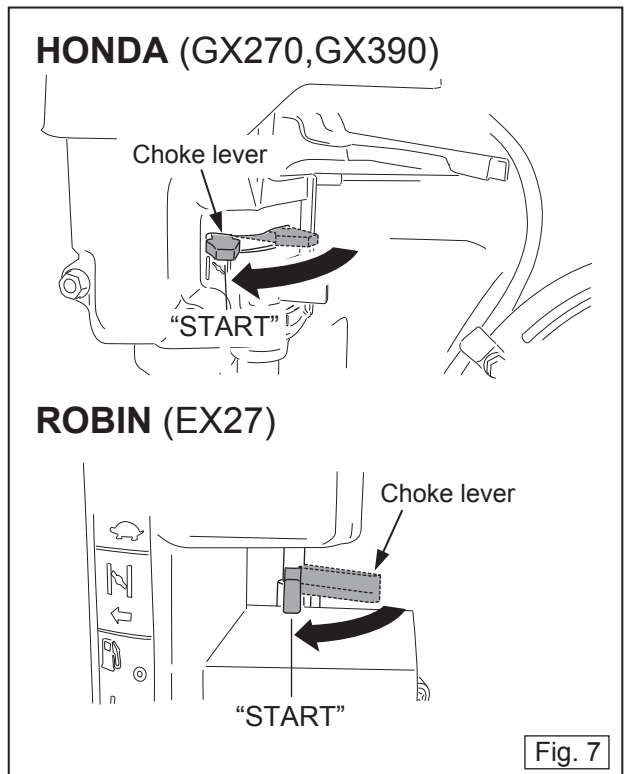

- 3 Move the throttle lever to the idle position. (Fig. 8)

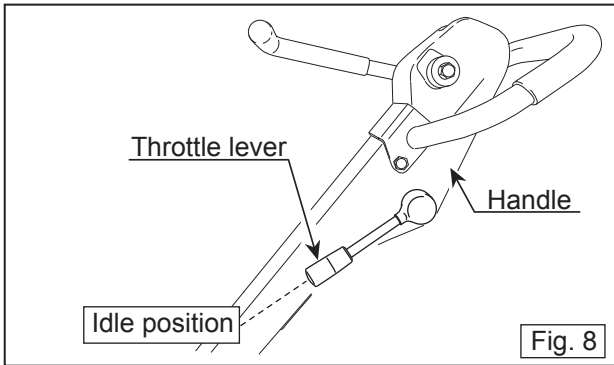

- 4 When the engine is stopped, the hour tachometer is always showing "Cumulative time".(Fig.9)

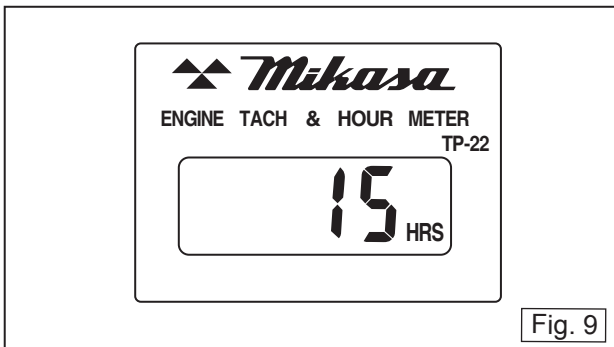

- 5 Turn on the engine switch on the rear cover. (Fig.10)

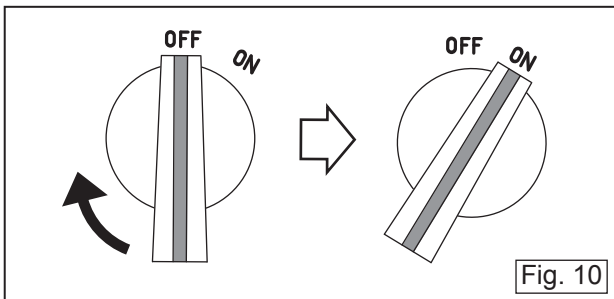

- 6 Hold the recoil starter grip, and pull it a little. You will feel a slight resistance. Then, pull it hard to run the engine. be careful not to pull too hard, or the rope might break or come off. Allow the starter rope to slowly move back into the case while keeping the grip grabbed. (Fig.11)

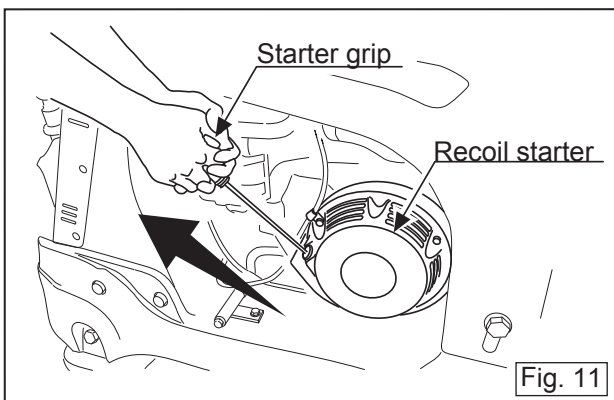

- 7 After the engine has started, while you hear some explosion loud noise, gradually move back the choke lever until it is wide open. (Fig.12)

When the choke lever is set to "Start", gradually move it back toward the "Operation" direction while making sure the engine revolution stabilizes.

HONDA (GX270,GX390)

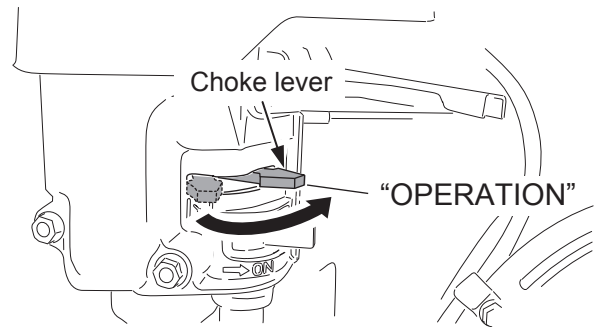

ROBIN (EX27)

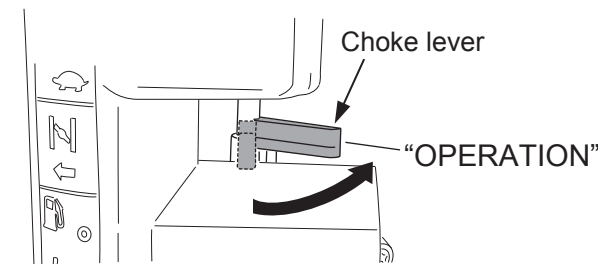

Fig. 12

- 8 After the engine has started, warm up the engine at low speed for 2 to 3 minutes. This is especially important in cold weather.

- 9 "Rotation number" is displayed during operation.(Fig.13)

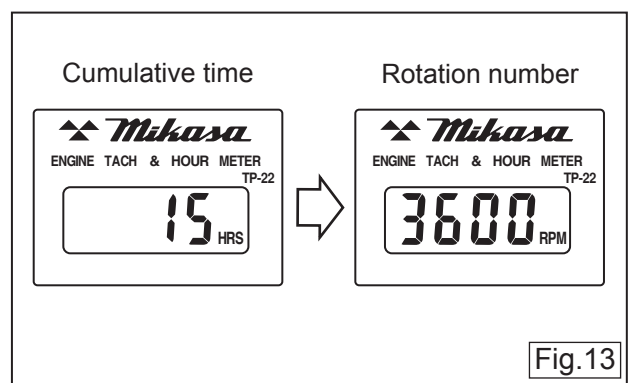
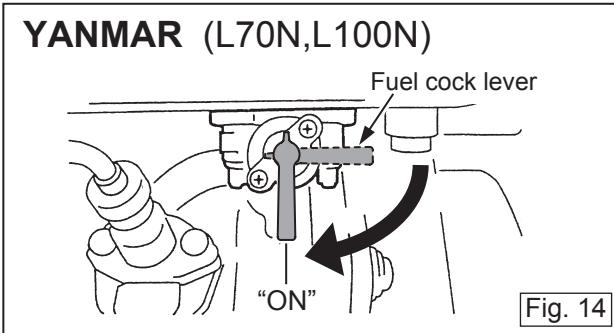

Fig.13

Diesel Engine

Set the fuel cock lever to the "ON" position to let the fuel flow.(Fig. 14)
(Only for YANMAR engine)



● Starter motor

- 1 Insert the key to the key switch.
- 2 Open the throttle lever to the idling position. (Fig.15)

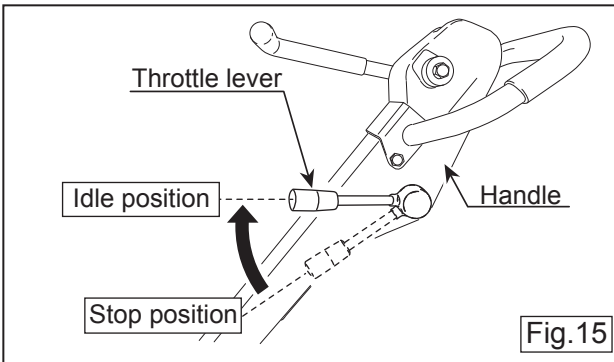

- 3 Turn the key to "Run" position. (Fig.16)
The buzzer starts. After "HA" is displayed on hour tachometer, the display will change immediately to "Cumulative time".(Fig.17)

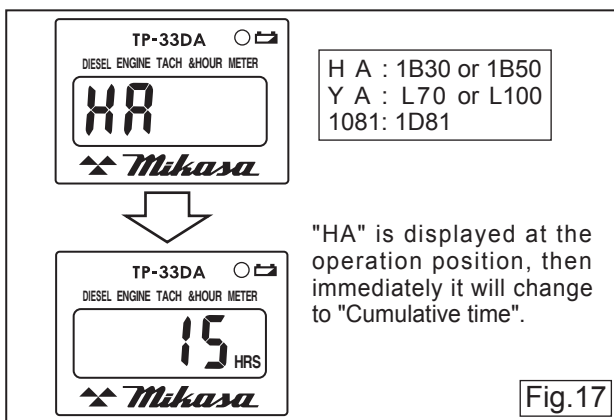
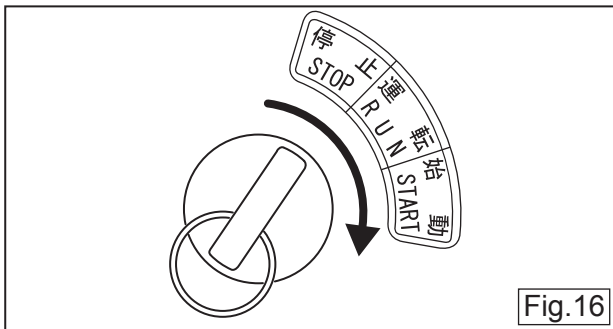

- 4 Turn the key further to the "START" position to start the engine. After the engine is started, take your hand off the key.(Fig.16)
After the engine revolution rises, the buzzer stops.

- 5 "Rotation number" is displayed during operation.(Fig.18)

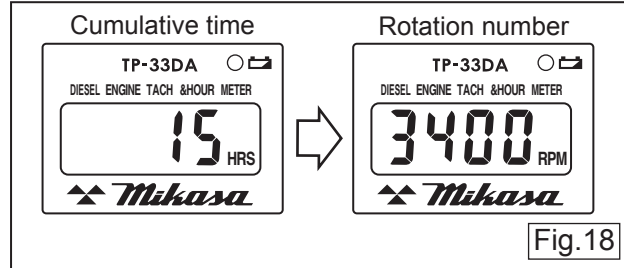

- 6 After the engine has started, warm up the engine at low speed for 2 to 3 minutes. This is especially important in cold weather.

CAUTION

- When the engine does not start, do not run the cell motor continuously for more than five seconds. Move the key back to the "RUN" position, then wait for about 10 seconds to restart.
- While the engine is running, never turn the key switch to the "START" position.

Diesel Engine

● Recoil motor

- 1 Insert the key to the key switch.
- 2 Open the throttle lever to the idling position. (Fig.15)
- 3 Turn the key to "Run" position. (Fig.16)
The buzzer starts. After "HA" is displayed on hour tachometer, the display will change immediately to "Cumulative time".(Fig.17)
- 4 Hold the recoil starter grip, and pull it a little. You will feel a slight resistance. Then, pull it hard to run the engine. be careful not to pull too hard, or the rope might break or come off. Allow the starter rope to slowly move back into the case while keeping the grip grabbed. (Fig.19)

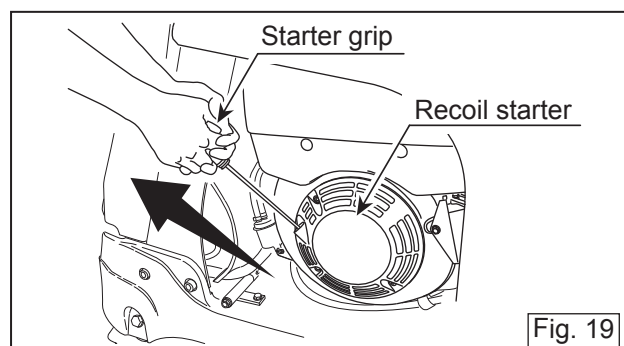

- After the engine has started, warm up the engine at low speed for 2 to 3 minutes. This is especially important in cold weather.

CAUTION

- Do not pull the starter knob all the length of the rope.
- After engine start, do not let the starter knob off your hand, but return it slowly by holding it. If you let the knob off at the position where it is pulled, the rope retracts suddenly, leading to breakage of the recoil starter and engine.
- While the engine is running, never turn the key switch to the "START" position.

8.2 Operation

CAUTION

- During operation, pay sufficient attention to dangerous objects, obstacles, in the direction of your work and surrounding area.
- While in operation, never touch the moving parts and high temperature parts of the machine.

- If the throttle lever is opened suddenly, the machine starts to operate. When you operate the throttle lever slowly, it may cause failure of the clutch causing the bad connection. (Fig.20)

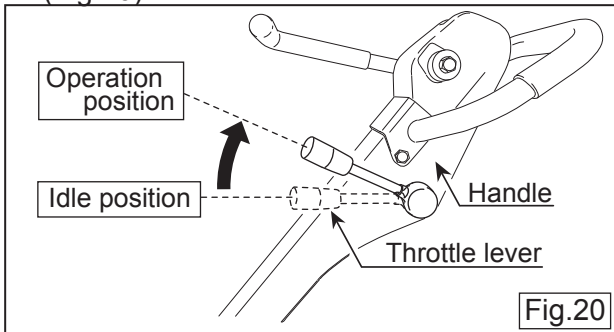

- Use the back and forth movement direction control lever to make the machine move backward and forward. When the direction control lever is pushed forward, the machine moves forward, when pulled backward, the machine moves backward. At neutral, the machine vibrates staying at the same location. (Fig.21)

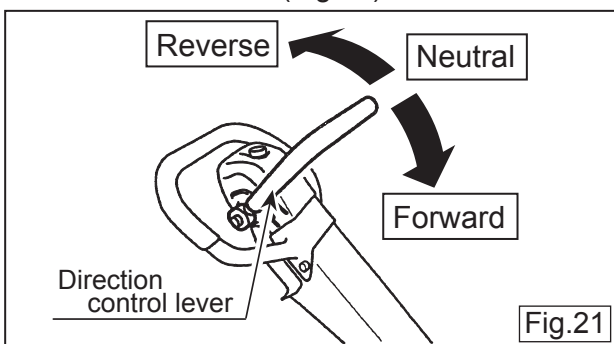

- When this machine is used on ground that contains clay, the ground surface tends to stick to the vibrating board, and the machine travel speed becomes slower. In this case, check the bottom of the vibrating board to see if there is any clay adhered to the board.

This machine cannot perform well on clay and other type of ground with a high water percentage. Drying the ground is recommended to make the ground water percentage appropriate for the machine to get good compacting performance.

- If you want to suspend the work, to return quickly to the idle position the throttle lever. (Fig.22)

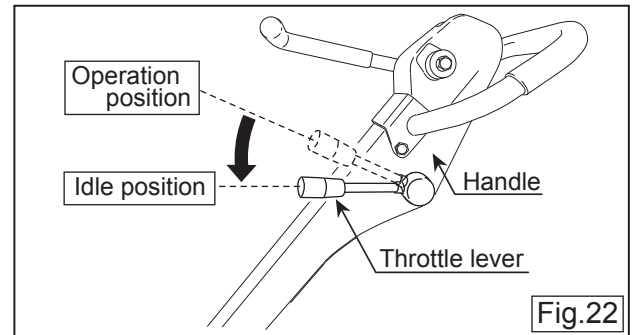

CAUTION

When you move to the idle position the throttle lever, please do not return to the operating position rapidly the throttle lever before the rotational speed is possible fall.

8.3 Compaction Sensor (Compass)

Compaction sensor (Compass) is a system that uses acceleration sensor to show real-time soil stiffness with LED (light-emitting diode) lights based on the number of compactions done.

This compaction sensor improves efficiency of compaction work because it can prevent the area already properly compacted from being compacted more than necessary and to identify the area where more compaction is needed. The sensor also has a function to detect abnormality such as vibration trouble (insufficient vibration frequency), ground trouble (soft soil) and functional issues. (Fig. 23)

NOTE

What is shown by the compaction sensor (Compass) is not the absolute value of the soil stiffness.

When using the sensor, always calculate appropriate soil stiffness by conducting plate load test and dynamic load test (FWD), etc. to calibrate the LED lighting level with the actual measurement value.

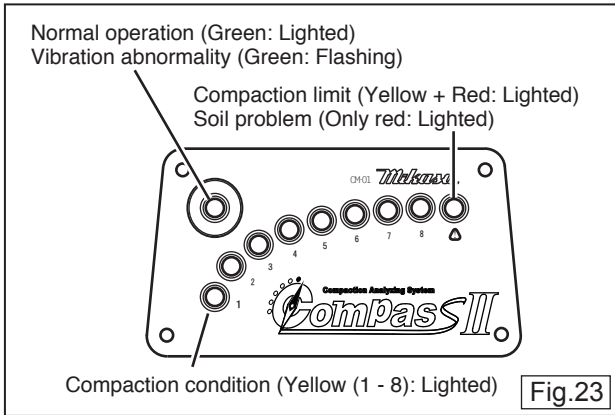

1 Normal compaction (during compacting)
Green LED lights up when the sensor finds that the machine is in normal compaction process. When the revolution goes up, and compaction starts, the yellow LED ① lights up, and as the compaction proceeds, the number of the lighted LEDs increases from ② to ⑧. After the LED light that was calibrated with the measured soil stiffness value lights up, the compaction process completes. (Fig. 24)

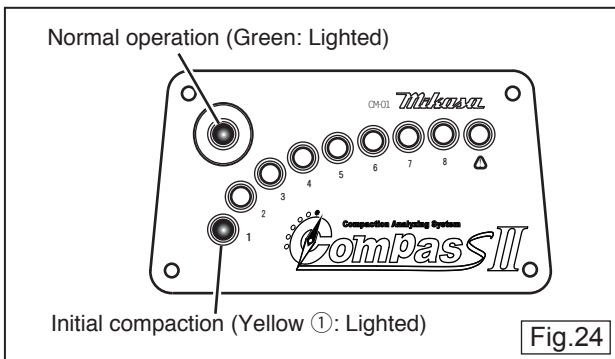

2 Normal compaction (Compaction limit)
Compaction limit is reached when all the yellow LEDs from ① to ⑧ have lit up and the red LED lights up. At this point, this machine cannot do any further compaction. If higher soil stiffness value is required, please use a machine of higher level. (Fig. 25)

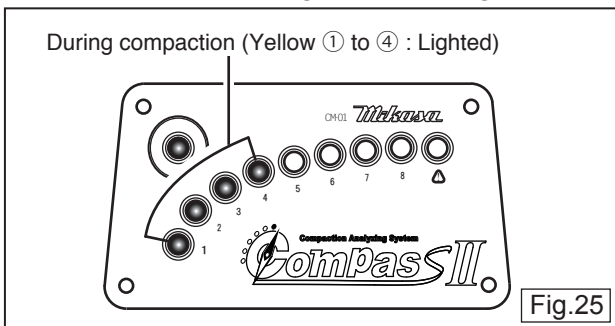

3 Function to detect abnormality

3-1 Detection of ground trouble and soft ground
For a case of unstable ground or soft ground (soil containing clay) for which the use of this machine is not suitable, only the red LED lights up, with no yellow LED illuminated.

If that happens, because you cannot expect sufficient compaction, do ground improvement work before proceeding with the compaction process. (Fig. 26)

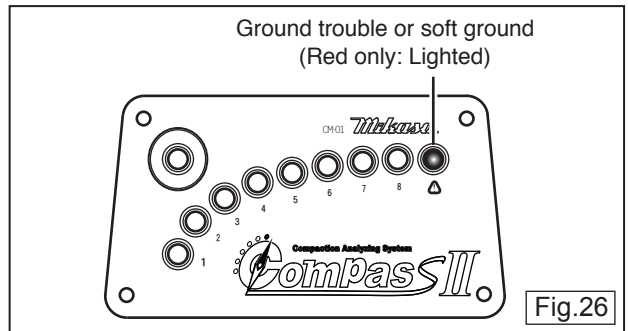

3-2 Detection of vibration abnormality
During operation when appropriate vibration frequency cannot be achieved because of the specified engine revolution or the loosened drive belt, or when the vibration frequency is too high, it is indicated by the flashing light. (Fig. 27)

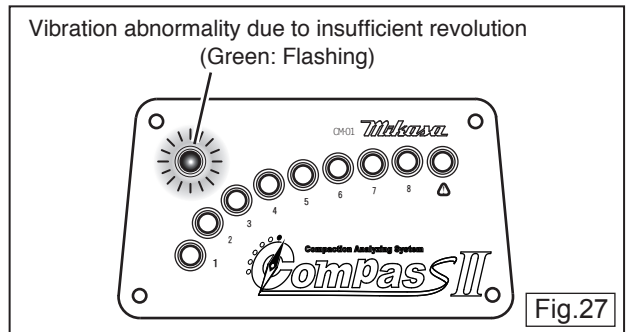

4 Function to detect electric system abnormality

4-1 Sensor wire disconnection
(Between acceleration sensor and sensor panel)
If flashing of red LED and green LED alternates as shown in the figure, please check the sensor wire because there is a possibility that it is disconnected. (Fig. 28)

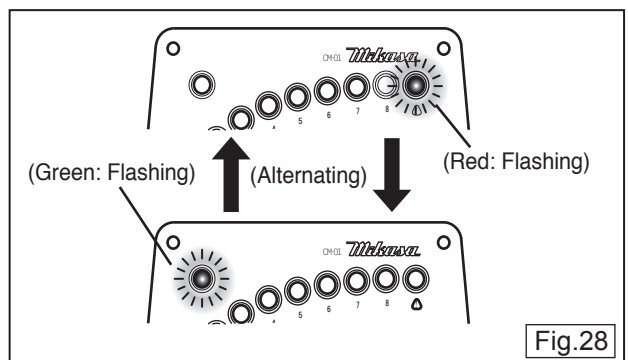

4-2 Power cable disconnection
(Between battery and sensor panel)
If there is no power even when the key switch is turned on, please check because there is a possibility that the power cable is disconnected.

9. STOPPING THE MACHINE

Gasoline Engine

- 1 Move the throttle lever to idle position.
Run the engine for 3 to 5 minutes at low speeds to cool it down before stopping.
- 2 Turn the engine switch to the OFF position, then the engine stops. (Fig. 29)

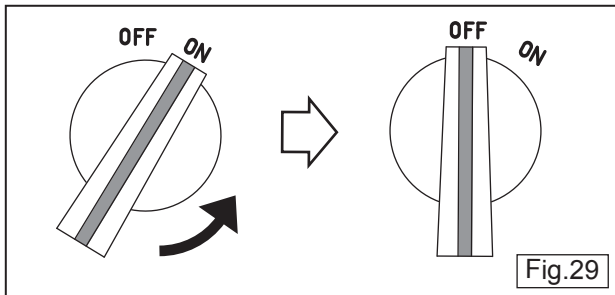

- 3 Shut the fuel cock. (Fig. 30)

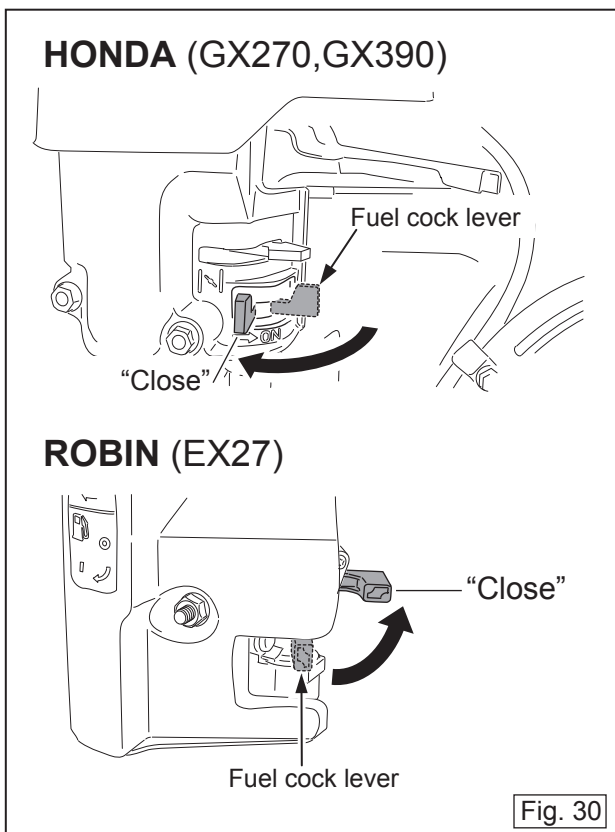

Diesel Engine

- 1 Move the throttle lever to idle position.
Run the engine for 3 to 5 minutes at low speeds to cool it down before stopping.
- 2 Move the throttle lever to the stop position to stop the engine.
In case of a diesel engine, when the engine stops, the buzzer sounds.(Fig.31)

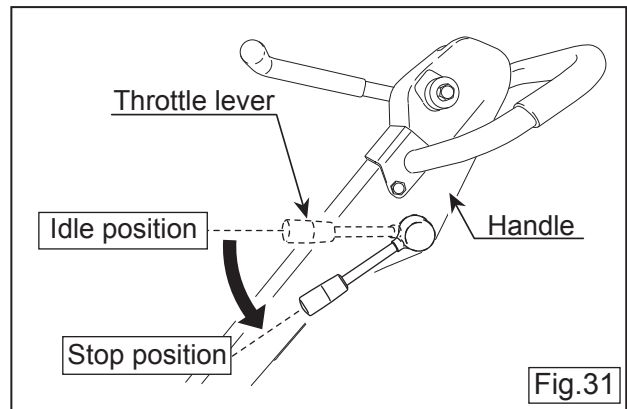

- 3 When the key switch is moved from "ON (Operation)" to "OFF(Stop)", the buzzer stops. (Fig. 32)

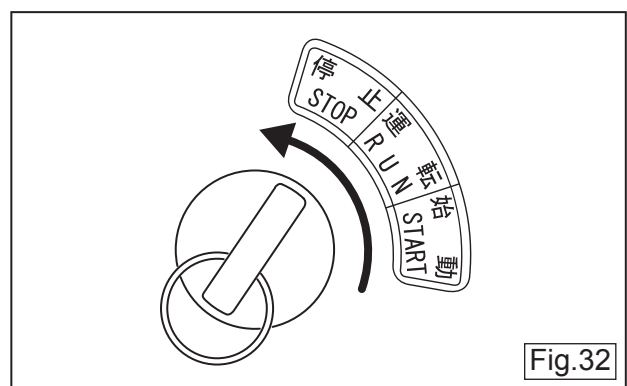

CAUTION

If the throttle lever is moved from the idling position to the stop position, the engine revolution decreases. Before the engine stops completely, do not move the throttle lever sud-

- 4 Shut the fuel cock.(Fig. 33)
(Only for YANMAR engine)

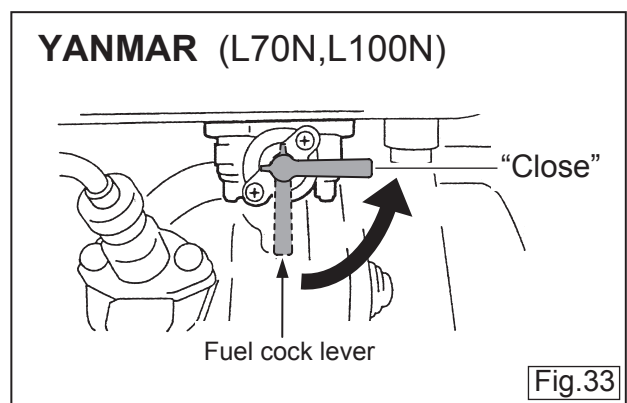

10. TRANSPORTATION AND STORAGE

10.1 Loading And Unloading

⚠ WARNING

- Make sure there is no breakage of guard frame and anti-vibration rubber nor loosened or missing bolts.
- Always stop the engine when lifting.
- Use an intact wire rope without any deformation with sufficient strength.
- Slowly lift upward without applying any impact. Never let people or animals go under the lifted machine.
- For safety reasons, do not lift to a height that is higher than necessary.

- 1 Use a crane for loading and unloading the machine.
- 2 Designate a person to guide the loading and unloading, and always work under the instruction of that person.
- 3 When lifting, always use a hook. (Fig. 34)
Never lift by using the hook on the handle.

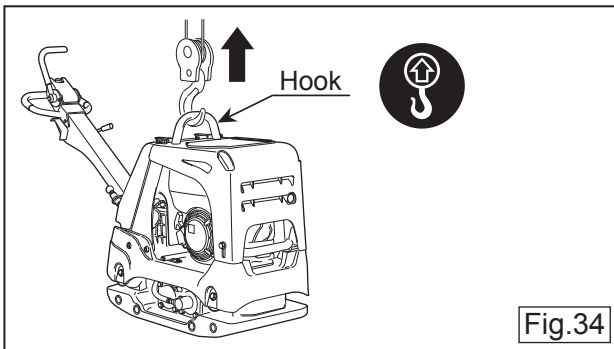

10.2 Transportation Precautions

⚠ WARNING

- Stop the engine when the machine is transported.
- Always drain the fuel before transportation.
- Fix the machine securely to prevent the machine from moving or falling.

- When putting the handle into the stored condition (vertical condition), make sure it is properly locked.
- When transporting, remove the starter key.

10.3 Storage

- Wash off dirt and soil from every part with water. While washing, be careful not to let the water splashed on the electric components such as the battery and the engine muffler part.

- Store in a dry area away from direct sunlight after putting the cover over the machine to prevent dust and dirt buildup.
- Do not leave the machine outdoors. Keep it indoors.
- When not used for a long period of time, drain the fuel from the fuel tank, and either disconnect the battery terminal or remove the battery itself.
- When the machine is used after a long storage period, check the level of engine oil and battery capacity.

11. REGULAR CHECK AND ADJUSTMENT

11.1 Inspection And Maintenance Schedule Table

Check frequency	Check parts	Check items	Oils
Daily (before starting)	Appearance	Flaw, deformation	
	Fuel tank	Leakage, oil level, dirt	Light oil, gasoline
	Fuel system	Leakage, oil level, dirt	
	Engine oil	Leakage, oil level, dirt	Engine oil
	Shock absorber	Crack, damage, wear	
	Hand pump	Leakage	Hydraulic oil
	Vibrator oil	Leakage	Engine oil
	Hydraulic pipe system	Leakage, looseness,flaw, wear	Hydraulic oil
	Air cleaner	Dust on sponge	
	Guard frame	Breakage, flaw, loosenedor missing bolts and nuts	
	Back and forth motion lever, linking parts	Missing, breakage, flaw,looseness or missing-bolts and nuts	
	Back and forth motion lever operation	Operation check, play	
	Bolts and nuts	Looseness, missing	
Duct hose	Crack, damage		
Every 20 hours	Engine oil	Replace only afterthe first 20 hours	
	Engine oil filter	Replace only afterthe first 20 hours	
Every 100 hours	Engine oil	Change	Engine oil
	Engine oil filter	Washing	
	Vibrator oil	Leakage, oil level, dirt	Engine oil
	Hydraulic oil	Leakage, oil level, dirt	Hydraulic oil
	Battery terminal	Cleaning	
Every 200 hours	V-belt for vibrator	Flaw, tension	
	Clutch	Dirt, flaw, wear	
Every 300 hours	Vibrator oil	Change	Engine oil
	Hydraulic oil	Change	Hydraulic oil
	Fuel filter	Change	
	Engine oil filter	Change	
Every 2 years	Fuel pipes	Change	
Irregular	Air cleaner element	Change	
	Hydraulic hose	Change	
	Cyclone cleaner	Cleaning	

For details about the check and maintenance of the engine, please refer to the attached engine operation manual.

Caution: The above table shows the check frequency for standard condition.

The check frequency may vary depending on the condition in which the machine is used.

For check of bolt and nut looseness and tightening, please see the following tightening torque list.

Tightening torque list (unit: kgf-cm, 1kgf-cm=9.80665N-cm)

		Thread diameter							
		6mm	8mm	10mm	12mm	14mm	16mm	18mm	20mm
Material	4T(SS41)	70	150	300	500	750	1,100	1,400	2,000
	6-8T(S45C)	100	250	500	800	1,300	2,000	2,700	3,800
	11T(SCM3)	150	400	800	1,200	2,000	2,900	4,200	5,600
	When the mating material is aluminum.	100	300~350	650~700	(Bolts used on the machine are all right-hand thread.)				

11.2 Opening The Front Cover

For a comfortable maintenance work.

CAUTION

- Do maintenance work in a place with a flat and hard surface to keep the machine stable.
- Start your work after the machine and engine cool down completely.
- Be careful to catch the finger when opening and closing the front cover.
- Do not touch the hot part because the engine and muffler become very hot.

- 1 Remove the bolts (M14x35) on the front cover. Loosen the bolts (M14x35) on the side of front cover. (Do not remove.) (Fig.35)

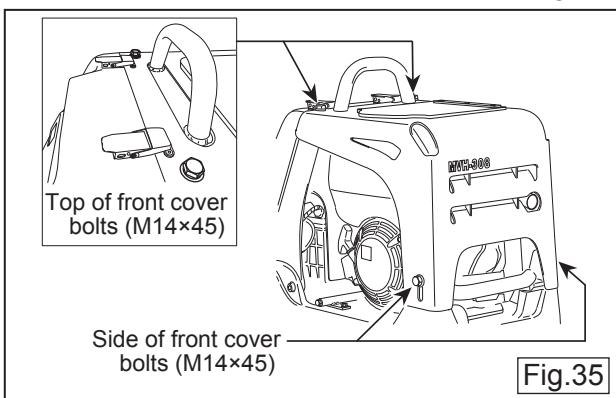

Gasoline Engine

- 2 Hold the side of front cover, and pull up to open position.(Fig.36)

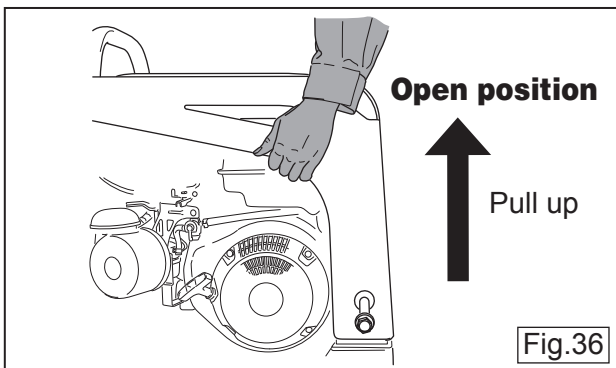

- 3 Open the front cover slowly.(Fig.37)

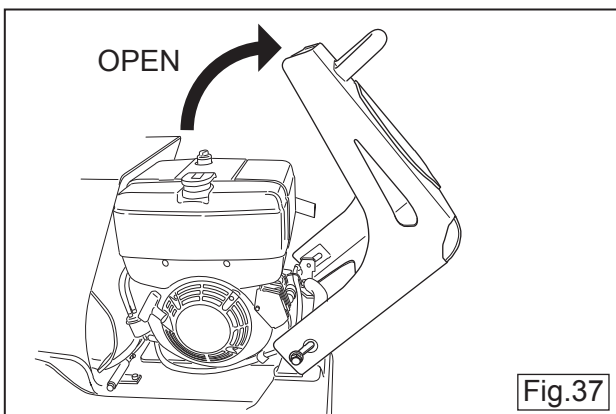

Diesel Engine

- 2 Hold the hook and the front side of front cover, and pull up to open position.(Fig.38)

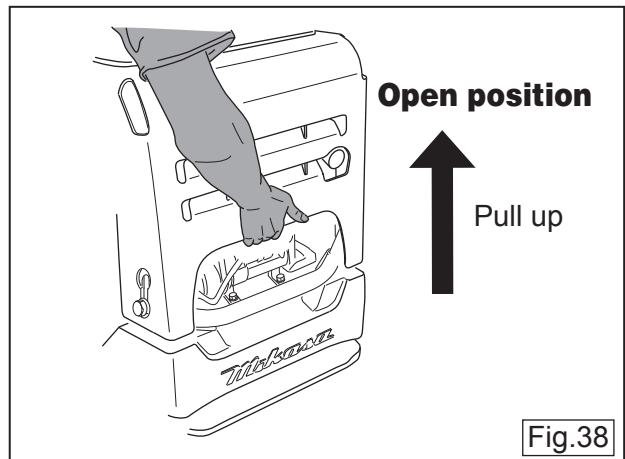

- 3 Open the front cover slowly.(Fig.39)

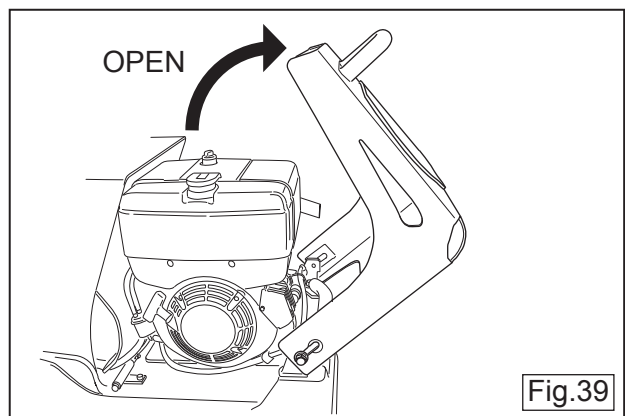

- 4 Return the front cover to original position slowly.Tighten the bolts in the specified torque. (Fig.40)

Size	Tightening torque	Remarks
Bolt M14X45	176.6N·m (130.2ft·lbf)	Apply Loctite #243

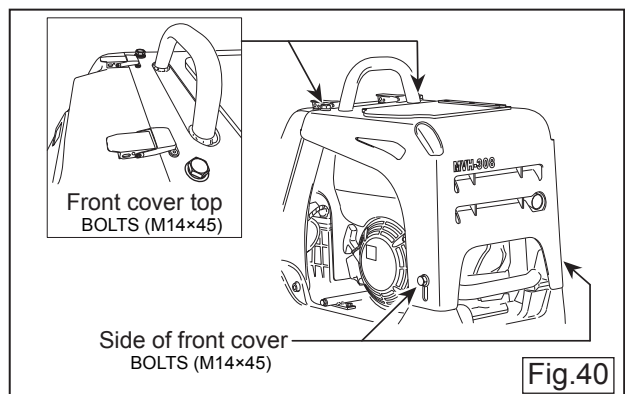

CAUTION

- Do not return the front cover in its open position.
- Do not start the engine when opening the front cover.
- Tighten the bolts firmly.

11.3 Changing The Engine Oil

- Perform the first engine oil change after 20 hours of operation, then change at every 100 hours.(Fig.41)

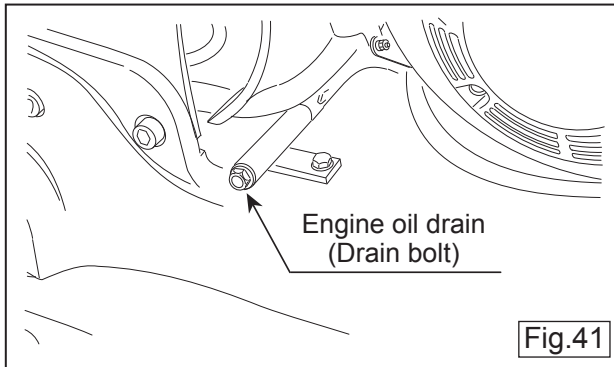

Fig.41

11.4 Cleaning The Air Cleaner

● The Engine Air Cleaner

When the air cleaner element becomes dirty, the engine does not start smoothly, and sufficient output cannot be obtained. Machine operation will be affected and the engine life will be shortened greatly. Do not forget to clean the element. (For details, please see the separate engine operation manual.) If the element cannot be cleaned, replace it with a new one.(Fig.42)

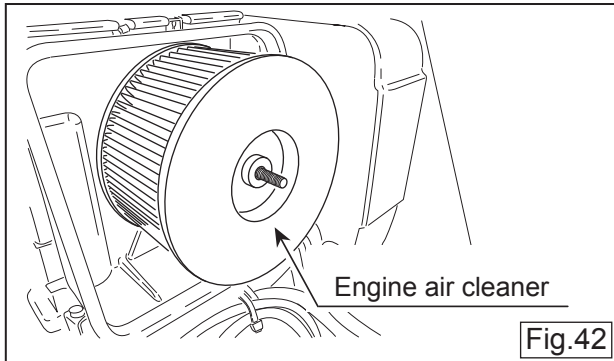

Fig.42

● Cyclone Cleaner

Always clean Dust Pot. Clogged Dust Pot leads to reduce cyclone effect with easy wear of Cleaner Element.

How to clean Dust Pot

- Latch off to remove Dust Pot. (Fig.43)

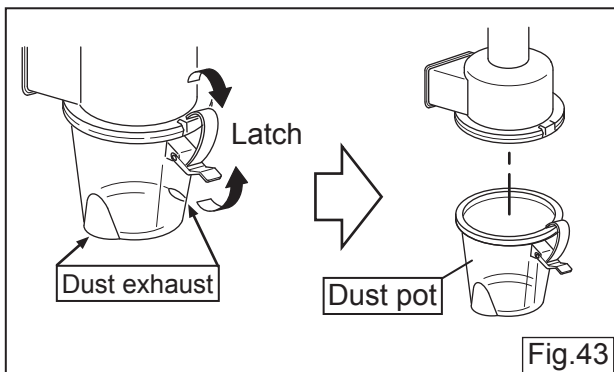

Fig.43

⚠ CAUTION

Be careful to avoid pinched fingers.

- Clean Dust Pot inside with water and neutral detergent.

⚠ CAUTION

Do not use organic solvent like paint thinner, which may cause damage or deformation of Dust Pot.

- Latch up securely to return Dust Pot to Air Cleaner.(Fig. 44)

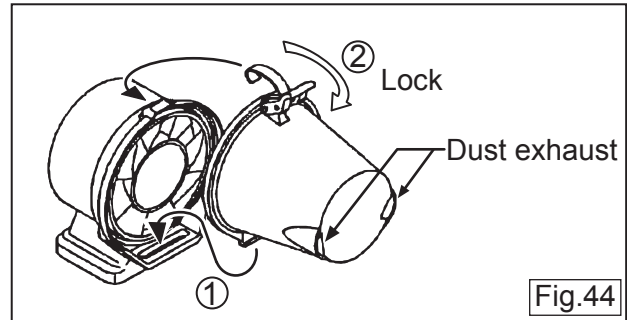

Fig.44

11.5 Checking/Changing The V-belt And Clutch

- Check of V-belt** (Fig. 45)

At every 200 hours, remove the belt cover (top) to check the tension of the V-belt. The flexibility of the belt should be about 10 mm when pushed strongly with your finger at the mid-point between the axes. When the V-belt is loose, the engine power is not transmitted well, resulting in poor compacting force and shortening the life of the V-belt.

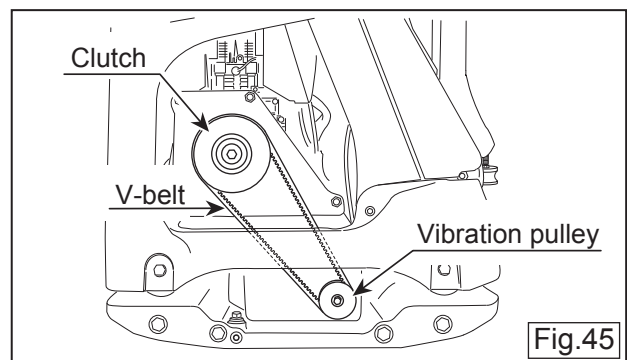

Fig.45

- Changing the V-belt**

● Removing the V-belt

Remove the top and bottom belt covers. Put a wrench (19mm) on the tightening bolt of the vibrator pulley (lower side). Put a piece of cloth at the center of the left side of the V-belt, and pull the belt strongly towards you. While pulling, turn the wrench clockwise, then remove the V-belt.

● Installing the V-belt

Set the V-belt on the lower side of the vibrator pulley. Push the V-belt to the left side of the upper clutch. Similar to removing the V-belt, turn the wrench clockwise to install.

⚠ CAUTION

- Stop the engine when inspecting or changing the V belt.
- Be careful not to have your hand or clothes get caught between the V belt and the clutch. Always wear work gloves.

11.6 Checking/Changing The vibrator Oil

At every 100 hours of operation, set the machine on a level surface and remove the oil gauge of the vibrator. Check the oil level to see if it is within the allowable range. (Fig.46)

Change the vibrator oil at every 300 hour operation. Drain the oil from the drain plug. For draining, put a beam under the compacting board at the other side of the drain plug to tilt the machine.

Use engine oil SAE 10W-30 as lubrication oil. The quantity used is 600cc.

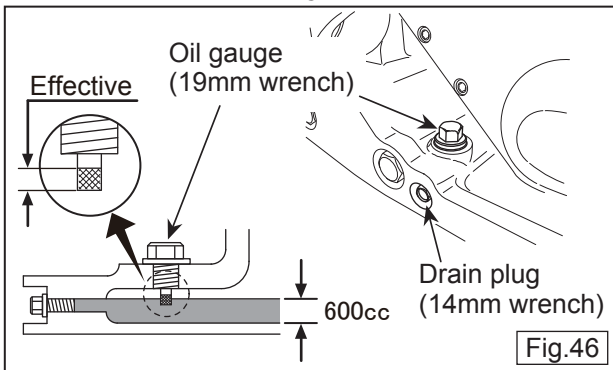

⚠ CAUTION

- Appropriate maintenance is required to ensure safe and efficient operation of the machine. Pay special attention to the parts used for lifting, if they are not maintained properly, it might result in a serious accident.
- When checking the vibrator oil, clean the oil port beforehand to prevent dust and other foreign materials from falling into the oil. Whenever there is an oil leakage from the vibrator, check the oil level.
- In case that oil is drained from Drain Plug, some oil still remains in Oil Pan. So be sure to check oil level correctly by Oil Gauge after filling oil.
- Do not fill oil with excessive volume (600cc). It may cause the terrible fuel consumption and lower machine performance as the result of engine overload.

11.7 Checking/Changing The Hydraulic Oil

● Check the hydraulic oil

Check the hydraulic oil at every 100 hours' operation. By making the handle bar vertical (done at the time of storage), remove the breather plug at the top of the hydraulic hand pump to see if the hydraulic oil is at the specified level (OIL LEVEL). (Fig. 47)

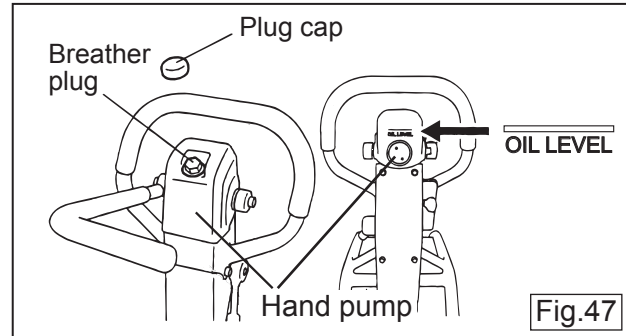

● Changing the hydraulic oil

- 1 Remove the plug cap of the hand pump. Then remove the breather plug (with 24mm wrench) before removing the hydraulic hose connected to the cylinder on the vibrator side. Set the run lever to reverse, then drain the hydraulic oil from the pump. (Fig.47, 48)

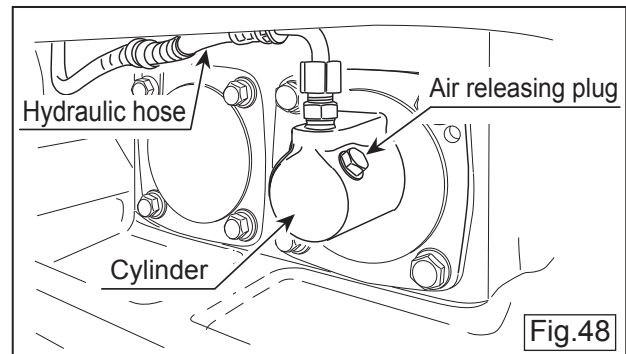

- 2 After the oil is drained, attach the hydraulic hose again to the cylinder on the vibrator side. With the direction control lever at the forward-most position, fix to the hook with a rope to immobilize. (Fig.48, 49)

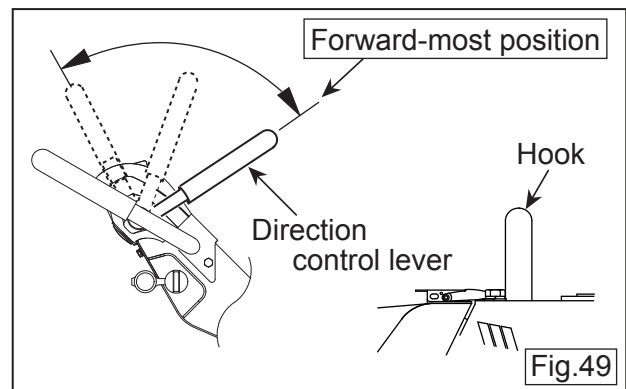

- 3 Pour hydraulic oil(550cc) from the hand pump breather plug attachment hole. (Fig.47)
- 4 Remove the air releasing plug of vibrator cylinder. Then oil will come out from the air releasing plug. After air bubbles stop coming out, attach the plug. Tighten securely. (Fig.48)
- 5 Then release the direction control lever and move the lever forward and reverse several dozen times (until air bubble not be found). Stay the lever at the forward position for 10 seconds every time. (Because the check valve is opened at the maximum forward position and air bubble will come out from the oil tank of the hand pump).(Fig.49)
In case the air bleeding is insufficient, repeat the procedure of above "4" and "5".
- 6 Attach the hand pump breather plug, put on the plug cap. After making sure the hydraulic oil in the pump is at OIL LEVEL, attach the breather plug.

CAUTION

The level of the hydraulic oil in the hand pump should always be at OIL LEVEL. If the level is higher, the oil bursts out from the breather plug.

Hydraulic oil:
Shell Terrace Oil #32 or equivalent

11.8 Battery

● **Checking the battery**

The standard battery installed is a maintenance free battery. It is not necessary to supply battery fluid. In case of a sudden voltage drop, the battery cannot be charged quickly, so it has to be replaced with a new one.

● **Check of battery capacity by battery checker**

When the battery charging level gets low, the battery checker of the hour tachometer lights up in red.(Fig.50)

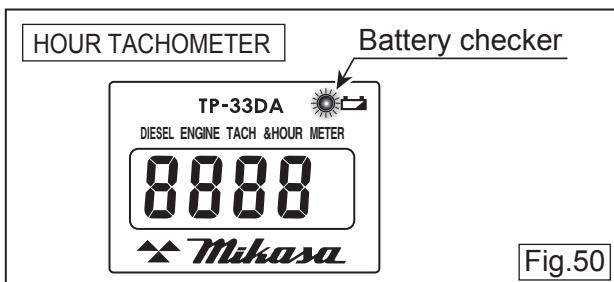

Fig.50

CAUTION

If an old battery is used, even when the battery checker is not lighted (indicating charging level low), the cell starter might not operate because of low charging level. If that happens, change the battery with the new one.

● **How to remove the battery**

- 1 Remove the stopper at the two locations on the top portion of the rear cover to open the rear cover.(Fig.51)

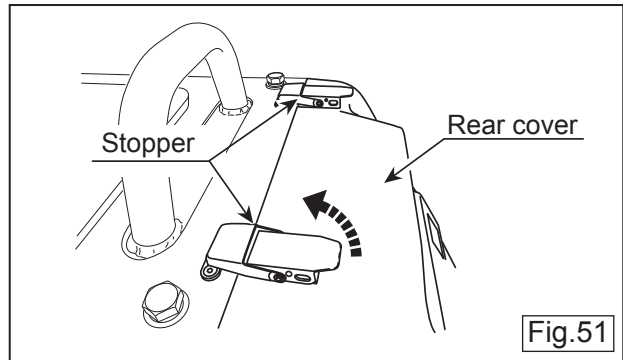

Fig.51

- 2 Loosen, but not remove, the M8 bolts (2 bolts) used for cyclone cleaner attachment. Take out the cyclone cleaner downward.(Fig.52)

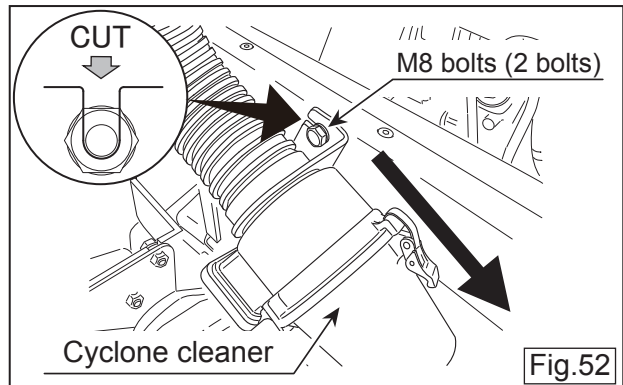
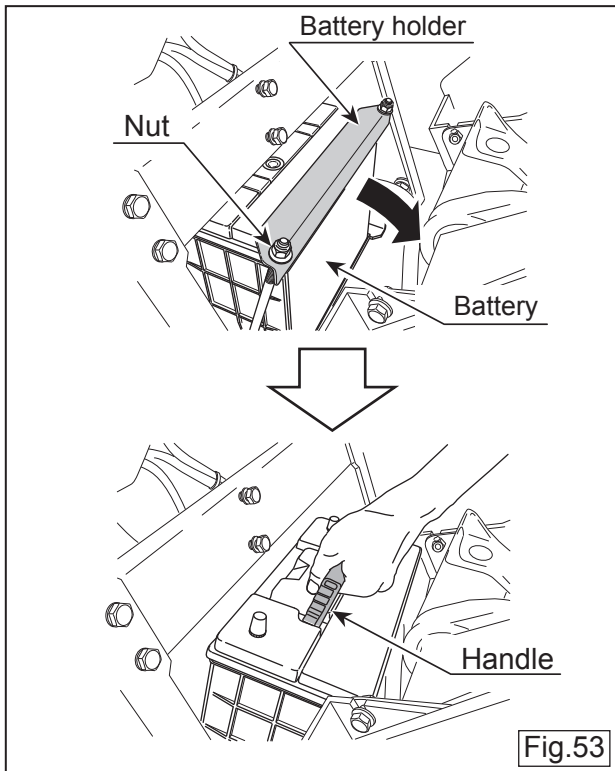

Fig.52

- 3 Take off the nuts and remove the battery holder. After tilting the battery backward, disconnect the battery terminal. When doing so, always disconnect the black terminal on the minus side first.
- 4 By holding the top surface handle, pull upward to remove the battery from the machine.(Fig.53)

CAUTION

Pay sufficient attention so that the battery terminal will not touch the frame.



5 For assembly, take the reverse steps described above, but when attaching the battery terminal, start with the red terminal of the plus side. Also, attach securely so that it will not get loosened by vibration.

CAUTION

When charging the battery, always remove it from the machine.

6 Mountable battery size table

	L	W	H	SIZE	
MVH-308	238	129	203	55B24L(JIS) No.51R(BCI)	STD
	245	175	175	DIN 55Ah or equivalent	Replacement
	245	175	190		
	245	129	203	JIS/BCI TYPE Maximum capacity	
	245	175	190	DIN TYPE Maximum capacity	
MVH-408	238	129	203	55B24L (JIS) No.51R(BCI)	STD
	232	175	203	※ 75D23L(JIS) No.35(BCI)	Replacement
	245	175	175	DIN 55Ah or equivalent	
	245	175	190		
	245	175	203	Maximum capacity	
MVH-508	232	175	203	75D23L(JIS) No.35(BCI)	STD
	245	175	175	DIN 75Ah or equivalent	Replacement
	245	175	190		
	245	175	203	Maximum capacity	

12. TROUBLESHOOTING

12.1 Gasoline Engine

(1) Starting problems

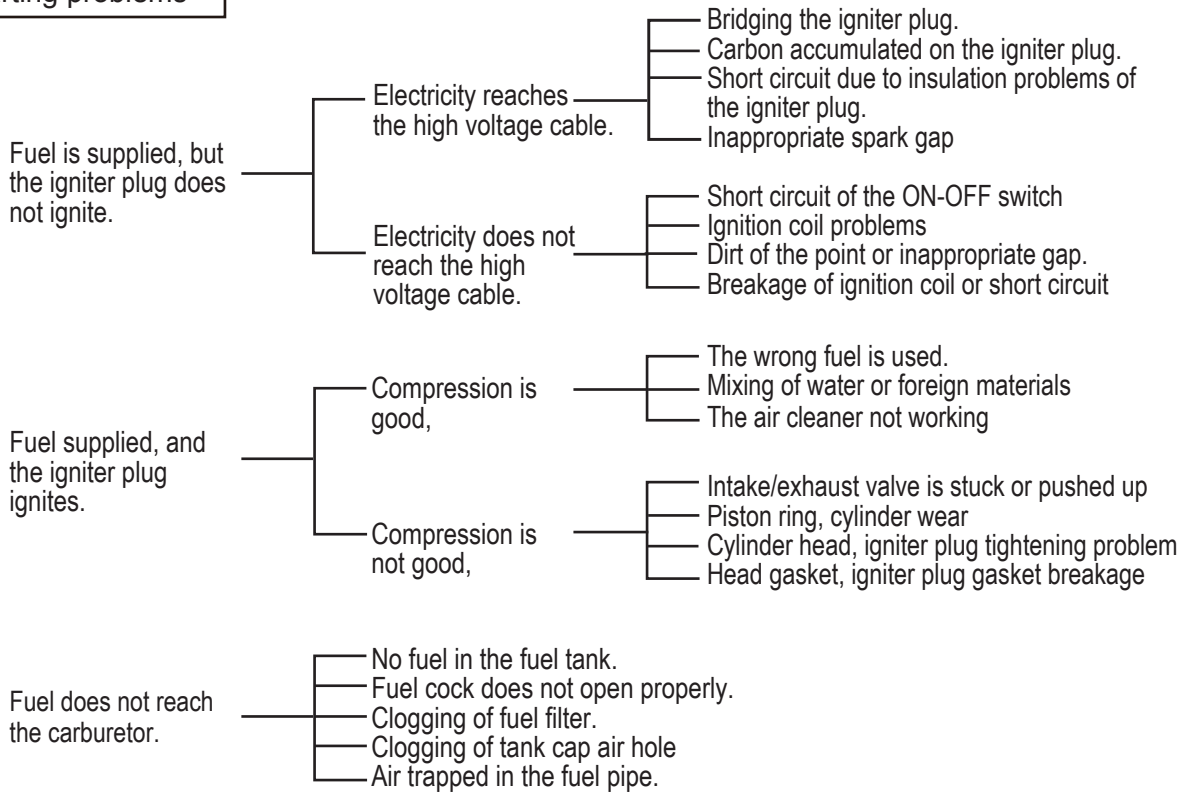

(2) Operation problems

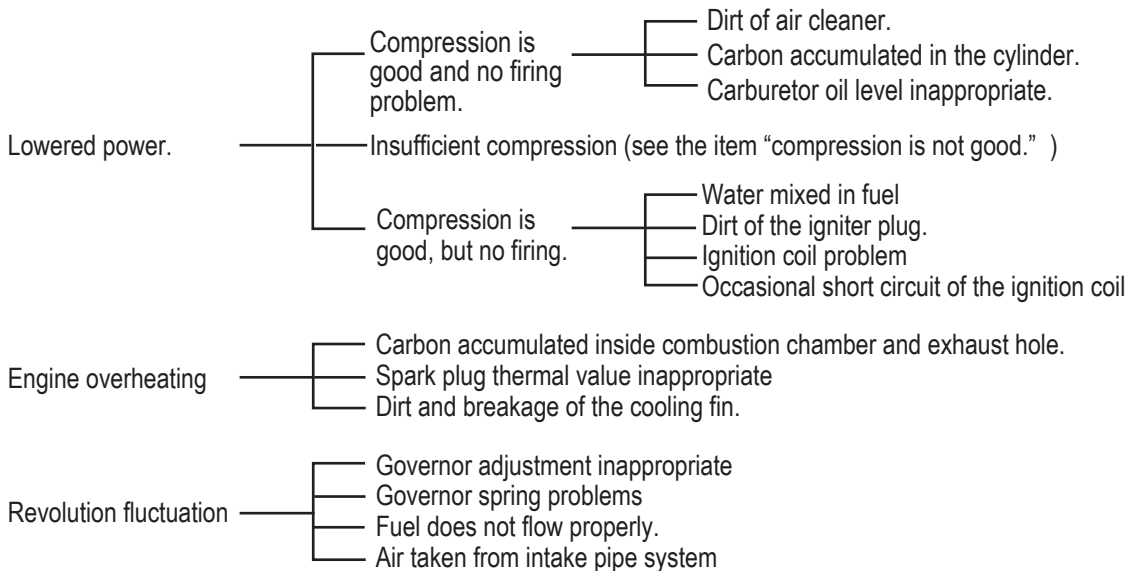

(3) Recoil starter problems

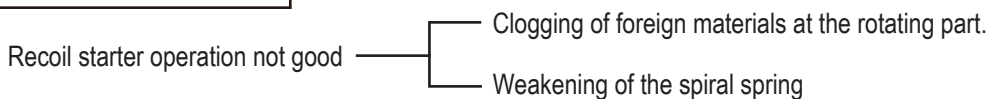

12.2 Diesel Engine

(1) Starting problems

(A) In case of compression problems

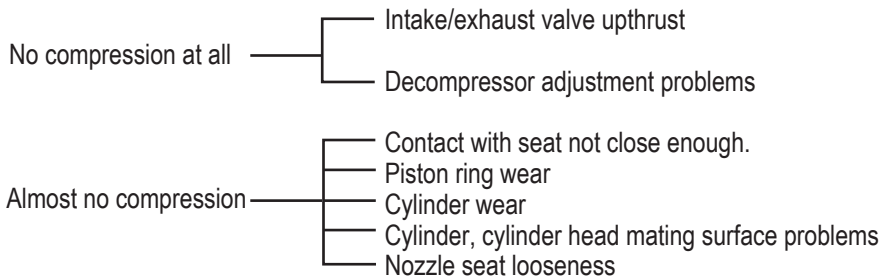

(B) In case of inappropriate fuel injection inside the combustion chamber

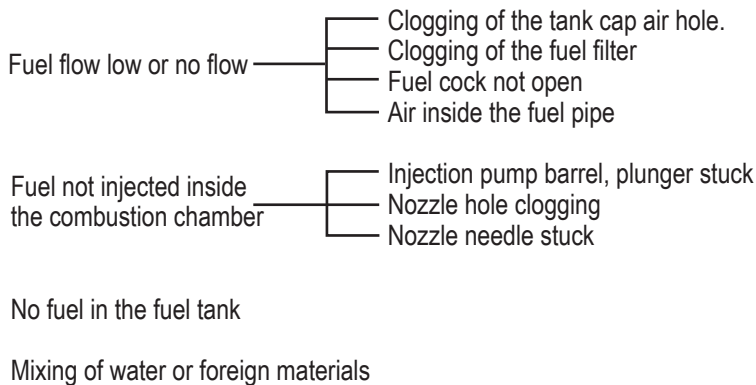

(C) Fuel and compression pressure appropriate, but the engine does not start.

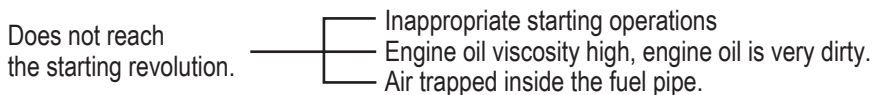

(2) Insufficient output and operation problems

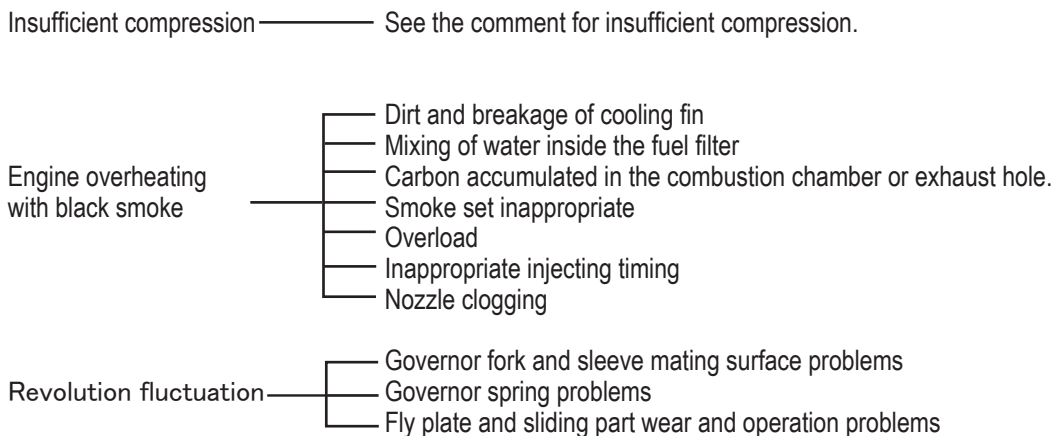

- Engine revolution does not increase. — Valve open/close timing inappropriate
 — Clogged exhaust hole, muffler
 — Overload
- Firing problem with white smoke (when unloaded) — Piston, cylinder ring wear
 — Nozzle hole clogging
 — Piston ring stuck
 — Wrong assembly (upside down) of piston ring
 — Inappropriate injection timing
 — Inappropriate valve open/close timing
 — Looseness of injection pump joint
- Fuel consumption too high (black smoke) — Leakage from fuel passage
 — Clogging of the air cleaner element
 — Inappropriate fuel due to mixing of impurities
 — Overload
- Extensive wear on sliding parts or stuck piston rings — Use of wrong oil
 — Failure to change oil
 — Breakage of the air cleaner element or failure to clean the air cleaner
- Stopped suddenly with abnormal noise — Searing or damage of the piston, rod, etc.
- Lubrication oil diluted and increased. — Wear on the injection pump barrel or plunger
- Engine does not stop even though the fuel supply is cut (or over-running) — Too much oil
 — Wrong assembly of the governor system
 — Detached injection pump rack

12.3 Main Body

- Low travel speed and vibration weak — Insufficient engine output and inappropriate high speed set revolution
 — Slipping of clutch
 — Slipping of V-belt
 — Too much vibrator oil
 — Failure inside vibrator
- Move forward or backwards, but unable to switch between back and forth motion — Hand pump problems
 — Inappropriately installed forward/backward motion lever
 — Breakage of the oil hose
 — Mixing of air in the hydraulic oil
 — Clogging of foreign materials in the check valve inside the hand pump
 — Breakage of the piston bearing in cylinder
- No forward, backward motion — V-belt coming off, slipping and breakage
 — Slipping of the clutch
 — Locking of the vibrator
 — Breakage of the piston bearing in cylinder
- Movement of lever heavy — Piston inside the hand pump not moving smoothly
 — Vibrator cylinder piston does not move smoothly

13. WIRING DIAGRAM

MVH-308DSY MVH-408DSY

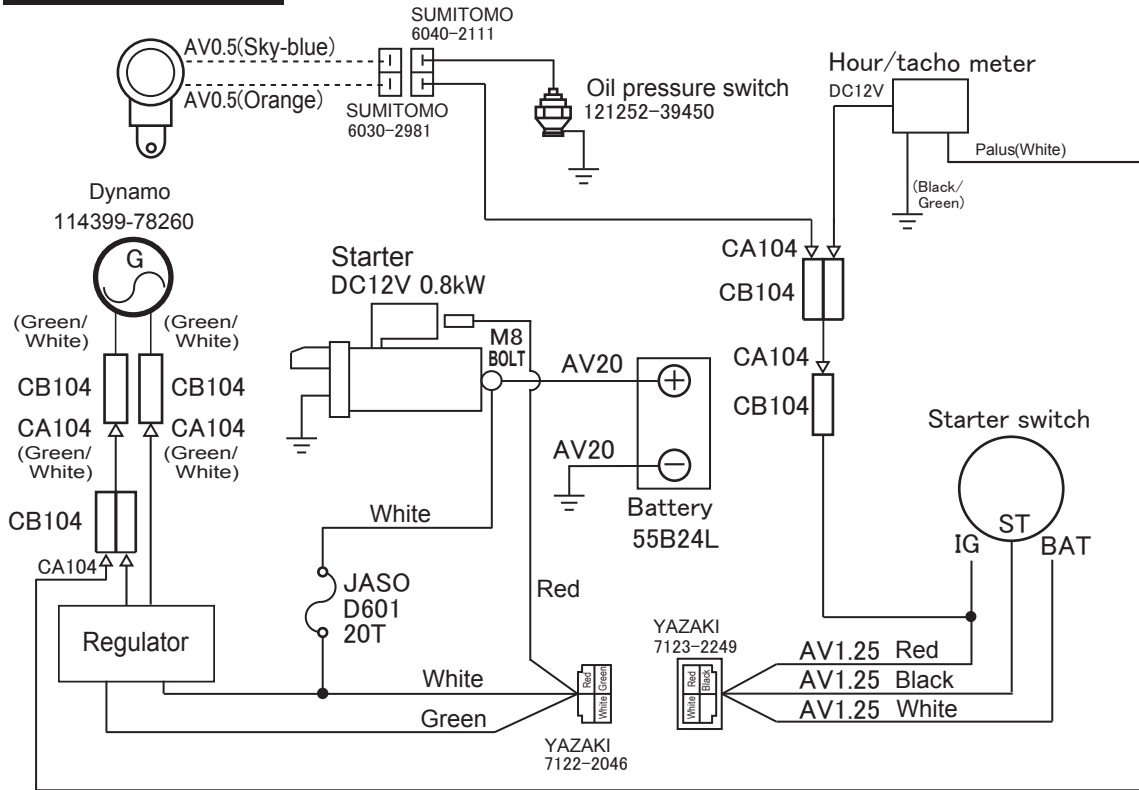

MVH-308DSY-PAS MVH-408DSY-PAS

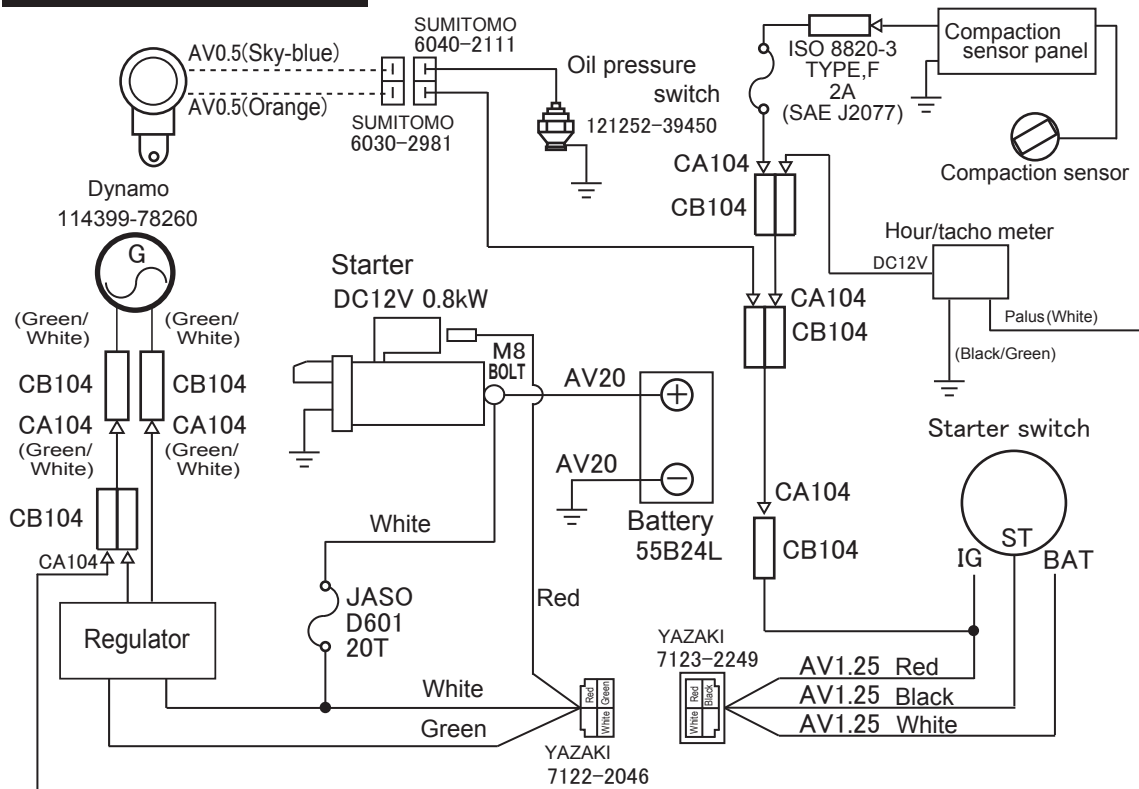

**MVH-308DSZ
MVH-408DSZ**

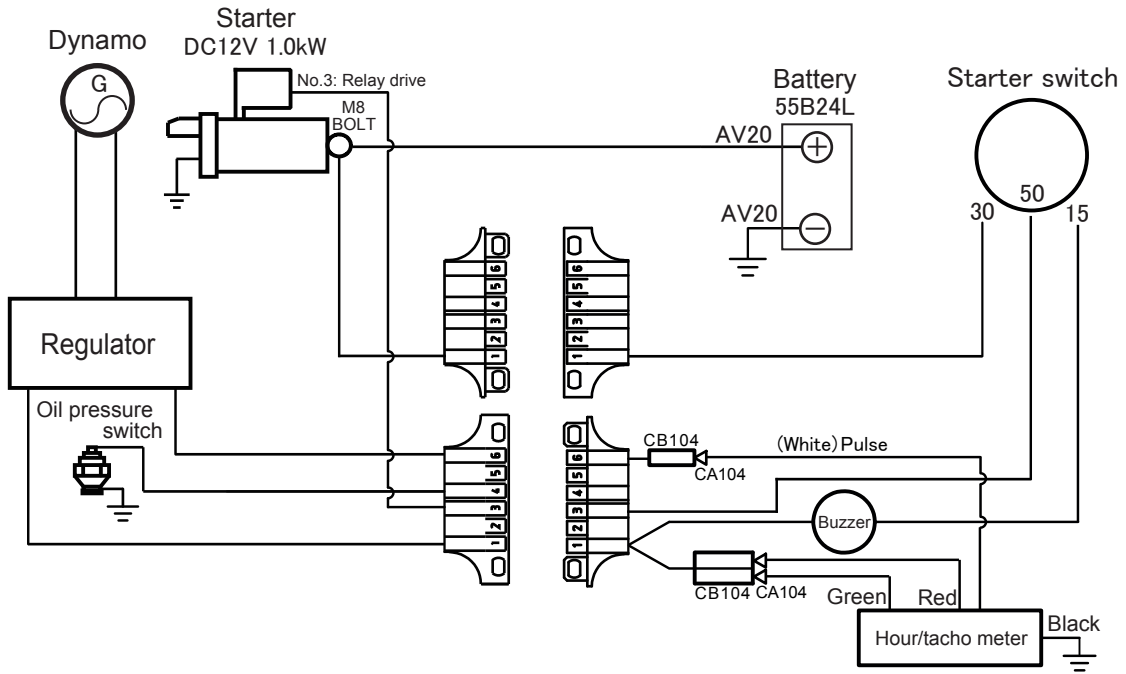

**MVH-308DSZ-PAS
MVH-408DSZ-PAS**

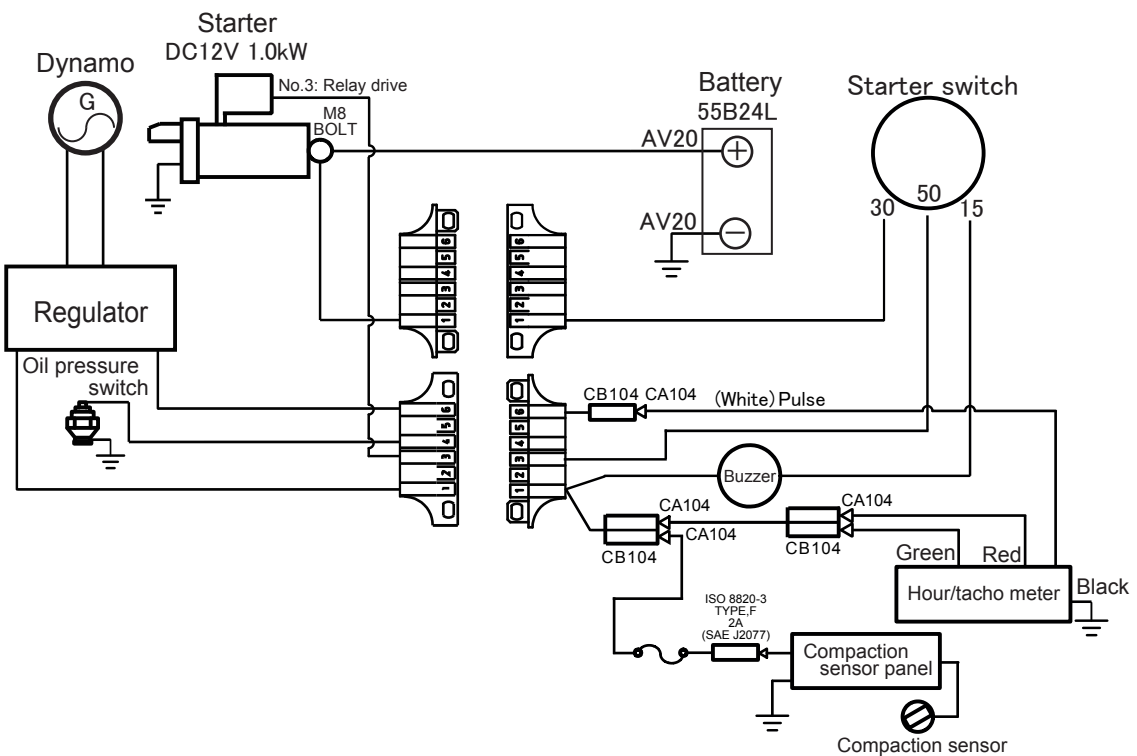

MVH-508DSZ

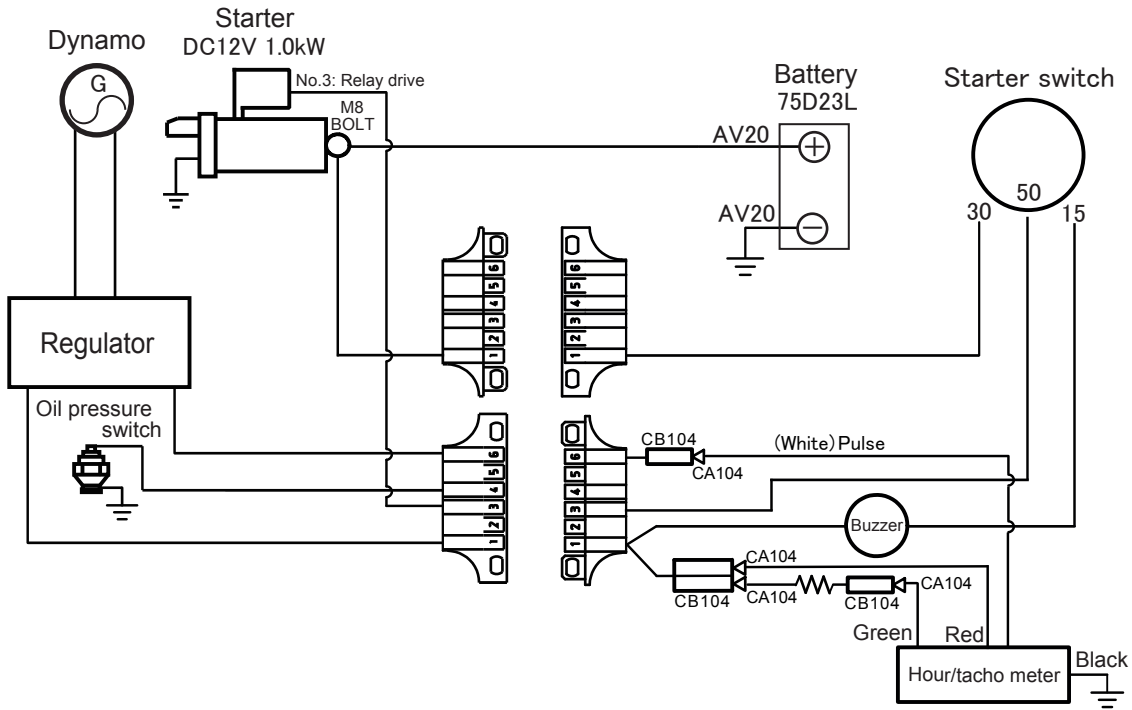

MVH-508DSZ-PAS

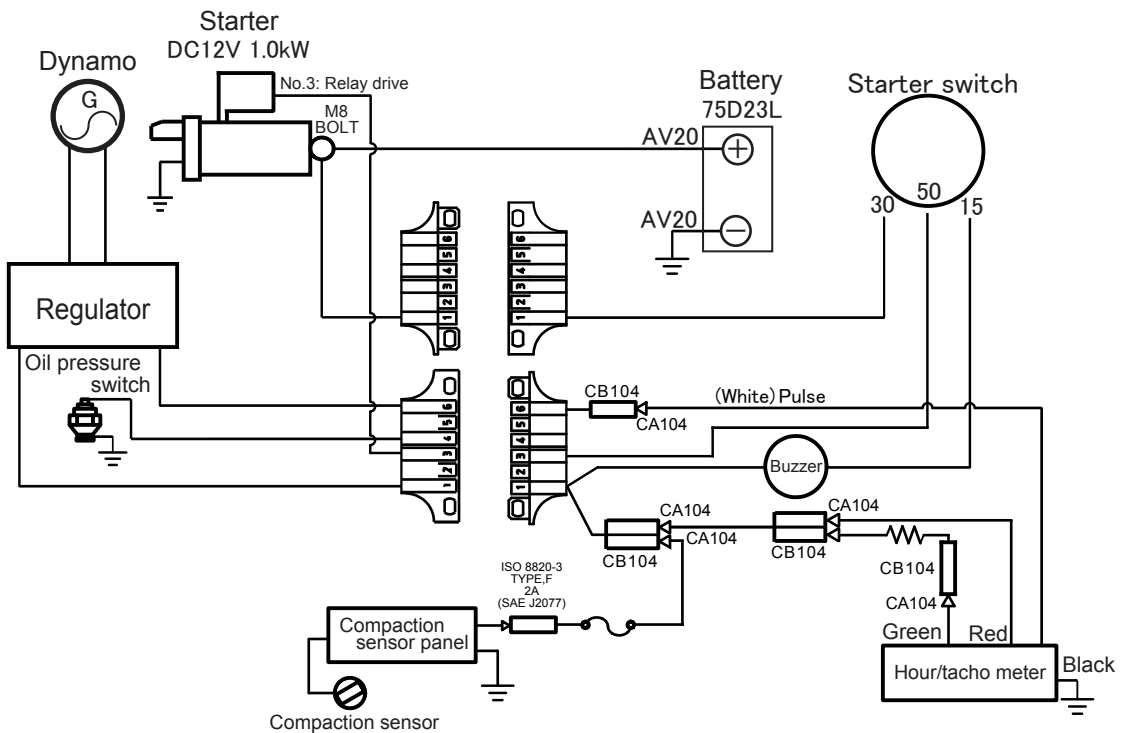



MIKASA SANGYO CO., LTD.

HEAD OFFICE
No.4-3, Sarugakucho 1-chome,
Chiyoda-ku, Tokyo, 101-0064,
Japan

<http://www.mikosas.com>