

3K 3307 / 3307 P



Vibratory compactor

- ▶ Ergonomic driver's compartment with unobstructed visibility
- ▶ Simple, automotive style instrumentation
- ▶ Continuous hydrostatic drum and wheel drive
- ▶ High performance, turbo-charged diesel engine that meets all current EPA emission requirements
- ▶ High gradeability through automatic, no spin differential and traction control system
- ▶ Unique 3-point articulation joint
- ▶ Hydrostatic steering
- ▶ Easy maintenance and long service intervals

TECHNICAL DATA

3307
3307 P

Weights

Operating weight with ROPS/FOPS	lbs (kg)	14,594 (6620)	14,594 (6620)
Maximum weight	lbs (kg)	17,196 (7800)	17,196 (7800)
Axle load, front/rear	lbs (kg)	8,686/5,908 (3940/2680)	8,686/5,908 (3940/2680)
Load per tire, rear	lbs (kg)	2,954 (1340)	2,954 (1340)
Static linear load, front	lbs / in (kg/cm)	131.6 (23.5)	

Machine Dimensions

Max. working width	in (mm)	66 (1680)	66 (1680)
Turning radius, inside	in (mm)	120 (3060)	120 (3060)
Padfoot - number of			112
Height of the padfoot	in (mm)		3.1 (80)
Top area of padfoot	sq. in. (cm ²)		17.6 (113)
Size of tires, rear		AW 14.9-24 8 PR	TR 14.9-24 8 PR

Diesel engine

Manufacturer		DEUTZ	DEUTZ
Model		TD 2011 L04 W	TD 2011 L04 W
Number of cylinders		4	4
Power rat. DIN/ISO30461FN kW/HP/rpm		68,0/92.5/2600	68,0/92.5/2600
Power rating SAE J1349, HP/kW/rpm		91.1/68,0/2600	91.1/68,0/2600
Fuel tank, capacity	Gal (Ltr)	46.2 (175)	46.2 (175)

Drive

Hydrostatic drive, front/rear		Hydraulic motor/axle	Hydraulic motor/axle
Speed, work range	mph (km/h)	0-4.2 (0-6.7)	0-4.5 (0-7.2)
Speed, transport range	mph (km/h)	0-7.8 (0-12.5)	0-7.4 (0-11.9)
Climbing ability, vibration on/off	%	54/59	65/70

Vibration system

Hydrostatic drive

Vibration

Vibration frequency, low/high	vpm (Hz)	1,800/2,520 (30/42)	1,800/2,520 (30/42)
Amplitude, high/low	in (mm)	.067/.024 (1,7/0,6)	.067/.024 (1,7/0,6)
Centrifugal force, high/low	lbs (kN)	28,125/21,375 (125/95)	28,125/21,375 (125/95)

Steering

Steering, type		Pivoted steering	Pivoted steering
Steering, actuation		hydrostatic, steering wheel	hydrostatic, steering wheel
Steering angle +/-	Grad	35°	35°
Oscillation angle +/-	Grad	10°	10°

Brake system

Service brake, mode of action		hydrostatic	hydrostatic
Service brake, actuation		Drive lever	Drive lever
Parking brake, mode of action		Spring-loaded/multi-disc	Spring-loaded/multi-disc
Parking brake, actuation		Electric and/or automatic	Electric and/or automatic
Emergency brake, mode of action		hydr./mech.	hydr./mech.
Emergency brake, actuation		Emergency stop button	Emergency stop button

Standard equipment

Suspended driving platform, access from either side. Sliding and swiveling operator's seat. 2 multifunctional drive levers. Traction control. Tilt steering wheel and instrument panel. Modern information and control display. Sound insulation. Tilttable GFK-engine hood. CE-conformity.

Optional equipment

Large capacity and comfortable ROPS cab with panoramic view, work lights, wipers front/rear, exterior and interior mirrors, and heater with dust free ventilation. Air conditioning. Radio. Hamm Compaction meter. Documentation system CDS. Tachometer. Speedometer. Frequency meter. Padfoot shell kit. Strike-off blade. Special paint.

Further data on request / subject to change

3307 - Vibratory compactor 3307 P - Padfoot compactor

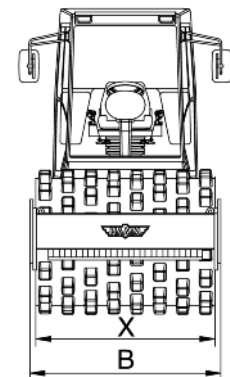
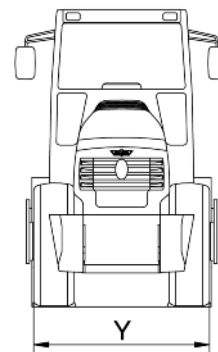
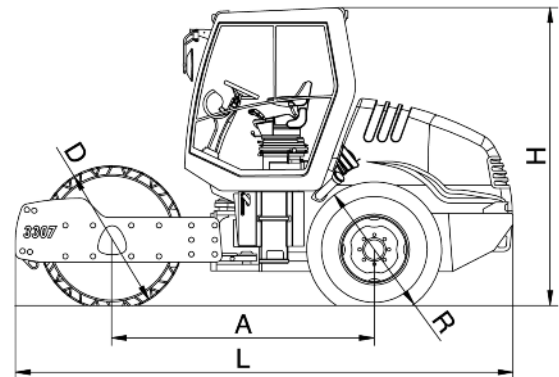
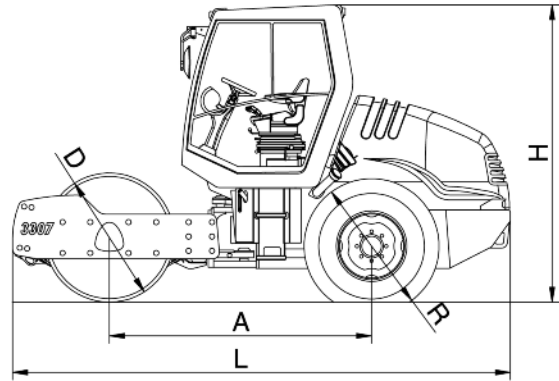

		3307	3307 P
Total length	L	184" (4680)	184" (4680)
Total width	B	70.5" (1790)	70.5" (1790)
Total height	H	110" (2790)	110" (2790)
Wheel base	A	97" (2465)	97" (2465)
Drum width	X	66" (1680)	66" (1680)
Drum diameter	D	48" (1216)	53.4" (1356)
Width over tires	Y	65" (1650)	65" (1650)
Diameter of tires	R	50" (1280)	50" (1280)

WIRTGEN AMERICA - HAMM COMPACTION DIVISION

6030 Dana Way • Antioch, TN 37013 • 615-501-0600 • 615-501-0691 Fax
www.hammcompactors.com