

260 MRT SERIES

MINI ROUGH TERRAIN SCISSOR LIFTS

JLG
reachingout®

Performance

Platform Height-Elevated	7.92 m
Platform Capacity	570 kg
Capacity on Deck Extension	140 kg
Lift/Lower Speed	27/21 seconds
Maximum Drive Height	Full Height
Gross Vehicle Weight*	3,700 kg
Drive Speed-Lowered	5.6 km/h
Drive Speed-Elevated	0.6 km/h
Gradeability	35%
Turning Radius (Inside)	2.13 m
Turning Radius (Outside)	4.39 m

* Certain options or country standards will increase weight.

Standard Specifications

Power

Diesel Engine	Kubota D1005 17.5 kW
Fuel Tank Capacity	28.4 L

Tyres

• Standard	Foam Filled Non-Marking
------------	-------------------------

Brakes

- Spring Applied Hydraulically Release

Hydraulic System

• Tank Capacity	56.8 L
• System Capacity	68.0 L

Standard Features

- 1.65 x 2.59 m Steel Platform
- 1.22 m Manual Roll-Out Deck Extension
- Fold-Down Platform Rails
- Moveable, Removable Platform Control Box
- Load Sensing System
- Flashing Amber Beacon
- Self-Closing, Self-Locking Inward-Closing Gate
- Cross Corner Four-wheel Drive
- Proportional Hydrostatic Drive Control with Thumb Steer
- Proportional Lift Up
- Horn
- Hourmeter
- Tilt Light and Alarm
- Lubrication-Free Scissor Arm Bushings
- Scissor Maintenance Prop
- Manual Descent Pull Cable
- Heavy Gauge Steel Chassis Hoods
- Nickel Plated Pins, Yellow Zinc-Chromate Plated Fasteners
- All Motion Alarm



Accessories & Options

- AC Outlet to Platform incl ELCB
- Squawker / White Noise Motion Alarm
- Wheel Chocks
- Platform Worklights

260 MRT SERIES

MINI ROUGH TERRAIN SCISSOR LIFTS

JLG
reachingout®

Dimensions

All dimensions are approximate.

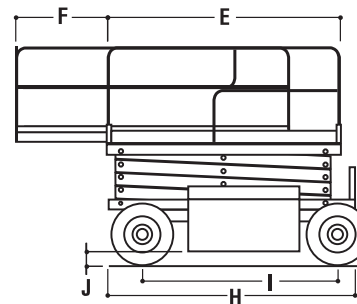
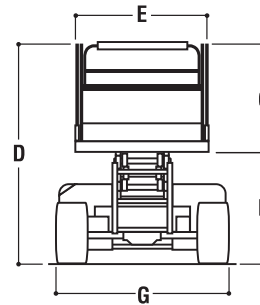
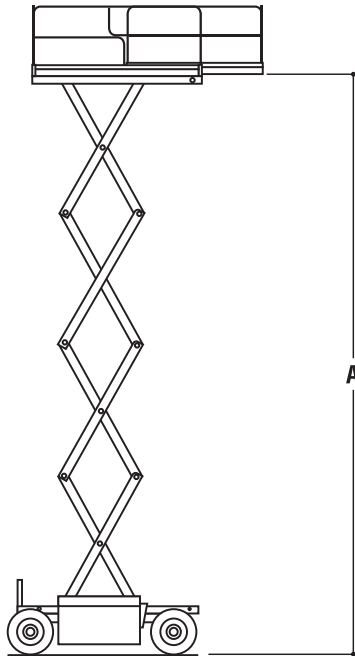

A. Platform Height Elevated	7.92 m
B. Platform Height Lowered	1.26 m
C. Platform Railing Height	1.1 m
D. Overall Height	2.37 m
E. Platform Size	1.65 x 2.59 m

F. Platform Extension	1.22 m
G. Overall Width (incl. Outriggers)	1.79 m
H. Overall Length (incl. Outriggers)	3.53 m
I. Wheelbase	1.98 m
J. Ground Clearance	20 cm

The JLG "1 & 5" Warranty

JLG Industries, Inc. backs its products with its exclusive "1 & 5" Warranty. We provide coverage on all products for one (1) full year and cover all specified major structural components for five (5) years. Due to continuous product improvements, we reserve the right to make specification and/or equipment changes without prior notification. This machine meets or exceeds AS/NZS 1418.10 2011 as originally manufactured for intended applications.

JLG

JLG Industries (Australia)

358 Park Road
Regents Park, NSW 2143
Telephone 02 8718 6300
Fax 02 8718 6377

www.jlg.com.au

An Oshkosh Corporation Company